

Index

Page	Schematics Page Name
01	Cover Sheet / Revision History
02	RBB_MCU7_V2.2_Top
03	RBB_MCU7_V2.2_MCU
04	RBB_MCU7_V2.2_Connector

Revision_History.SchDoc

Revision History

Rev.	Date	Author	Description	Page(s)
2.1	2019-10-09		Initial release	3
2.2	2020-04-02		Second release	4

Radar Baseboard MCU7

[No Variations]

2.2



Infineon Technologies AG

IFAG PSS RFS 3DS SAE RS

Am Campeon 1-15, 85579 Neubiberg, Germany

2020

LEGAL DISCLAIMER
 THE INFORMATION GIVEN IN THIS DOCUMENT IS GIVEN FOR ILLUSTRATING PURPOSES ONLY. THE RECIPIENT OF THIS DOCUMENT MUST VERIFY ANY FUNCTION DESCRIBED HEREIN IN THE REAL APPLICATION. INFINEON TECHNOLOGIES HEREBY DISCLAIMS ANY AND ALL WARRANTIES AND LIABILITIES OF ANY KIND (INCLUDING WITHOUT LIMITATION WARRANTIES OF NON-INFRINGEMENT OF INTELLECTUAL PROPERTY RIGHTS OF ANY THIRD PARTY) WITH RESPECT TO ANY AND ALL INFORMATION GIVEN IN THIS DOCUMENT.

Restricted

		Infineon Technologies AG	
		IFAG PSS RFS 3DS SAE RS	
		Am Campeon 1-15, 85579 Neubiberg, Germany	
Title Radar Baseboard MCU7			
Variant [No Variations]		Approved <Appr.>	
Size: A3	Document Name: Revision_History.SchDoc	Rel.	Rev. 2.2
Author: PSS RFS 3DS SAE RS			
Date: 02.04.2020 Time: 12:19:06		SVN Revision: Not in version control	
© Infineon Technologies 2020		Sheet 1 of 4	

RBB_MCU7_V2.2_Top.SchDoc

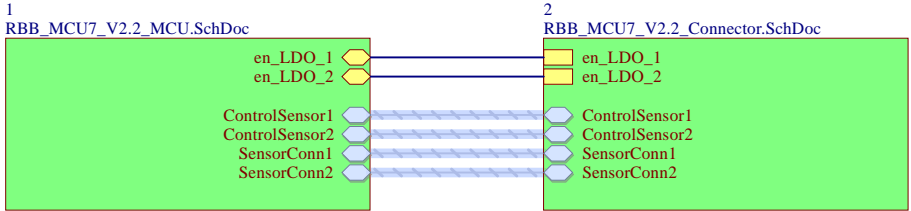

Restricted

Infineon Technologies AG
IFAG PSS RFS 3DS SAE RS
 Am Campeon 1-15, 85579 Neubiberg, Germany

Title		Radar Baseboard MCU7	
Variant		[No Variations]	Approved <Appr.>
Size:	Document Name	Rel.	Rev.
A4	RBB_MCU7_V2.2_Top.SchDoc		2.2
Author: PSS RFS 3DS SAE RS			
Date: 02.04.2020 Time: 12:19:06		SVN Revision: Not in version control	
© Infineon Technologies 2020		Sheet 2 of 4	

RBB_MCU7_V2.2_Connector.SchDoc

LDO 1

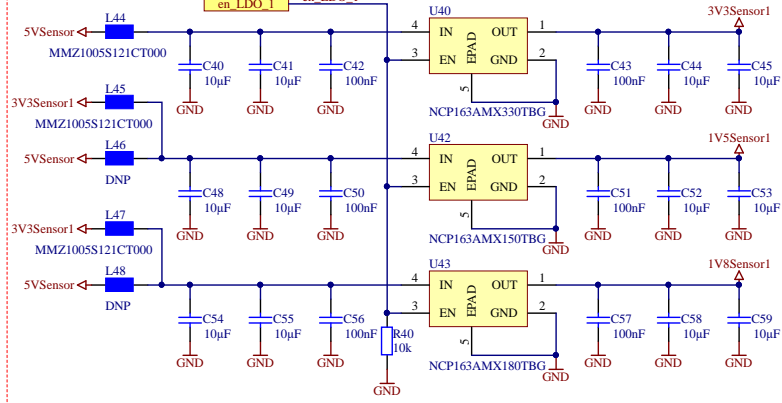

Level Shifter 1

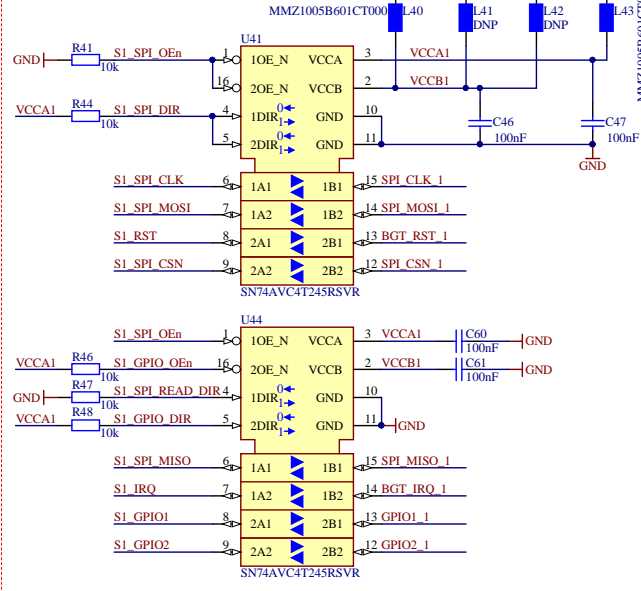

Sensor Connectors 1

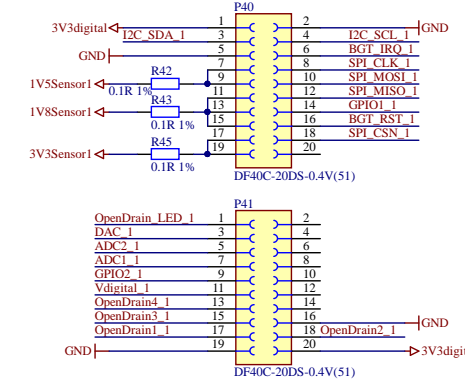

Harnesses

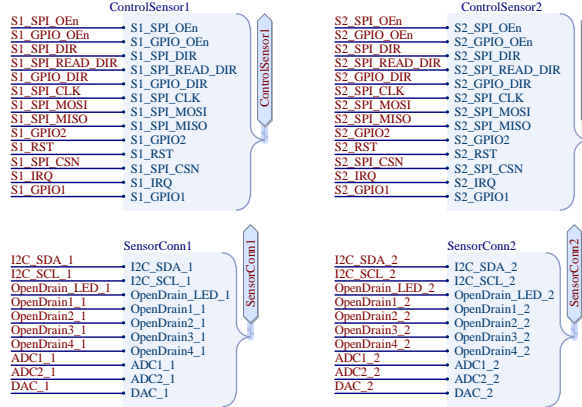

Level Shifter 2

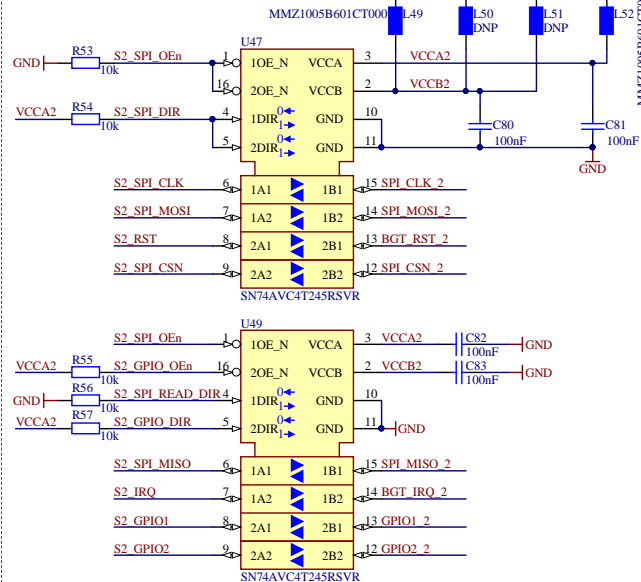

Sensor Connectors 2

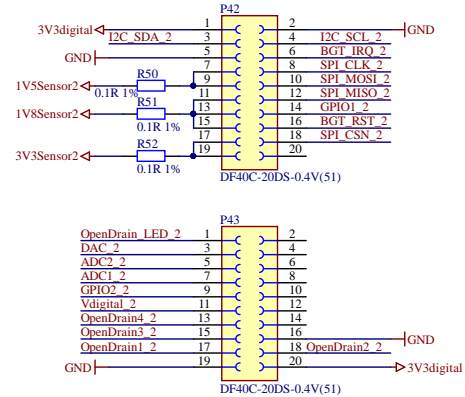

LDO 2

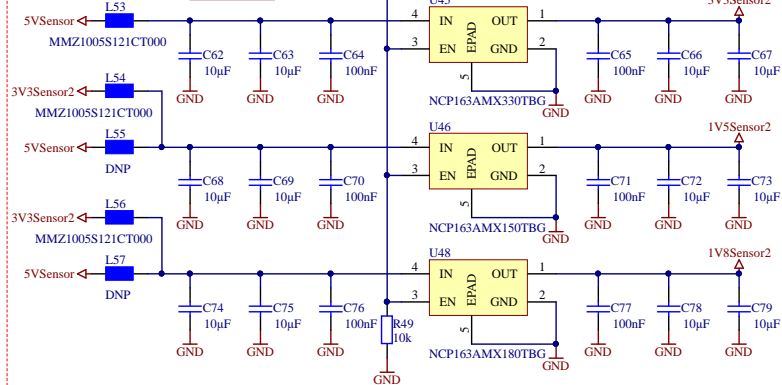

Restricted

Infineon Technologies AG
 IFAM PSS RFS 3DS SAE RS
 Am Campeon 1-15, 85579 Neuburg, Germany

Title: Radar Baseboard MCU7
 Variant: [No Variations] Approved <Appr.>
 Size: Document Name Rel. Rev.
 A3 RBB_MCU7_V2.2_Connector.SchDoc 1 2.2
 Author: PSS RFS 3DS SAE RS
 Date: 02.04.2020 Time: 12:19:07 SVN Revision: Not in version control
 © Infineon Technologies 2020 1 Sheet 4 of 4