

User Guide for XENSIV™ KIT CSK BGT60TR13C

About this document

Scope and purpose

This document is a user guide for the XENSIV™ KIT CSK BGT60TR13C, provided as part of the connected sensor kit (CSK) offering.

Intended audience

Customers interested in using CYSBSYSKIT-DEV-01 in combination with the XENSIV™ BGT60TR13C radar sensor or the XENSIV™ DPS368 barometric pressure sensor to build their own IoT solution for various consumer applications.

Important notice

Table of contents

About this document..... 1

Table of contents..... 2

1 Important notice..... 4

2 Introduction 5

2.1 Kit content5

2.2 CYSBSYSKIT-DEV-016

2.2.1 CYSBSYSKIT-DEV-01 main components6

2.3 XENSIV™ BGT60TR13C radar7

2.3.1 Key benefits8

2.3.2 Key features.....8

2.4 XENSIV™ DPS368 barometric pressure sensor9

2.4.1 Key benefits9

2.4.2 Key features.....9

2.5 Board details9

2.5.1 Kit and system block diagram9

2.6 Getting started.....11

2.7 Abbreviations12

3 Quick IoT Experience13

4 Build your own application.....24

4.1.1 XENSIV™ BGT60TR13C radar sensor library24

4.1.2 XENSIV™ DPS3xx pressure sensor library24

4.2 Code examples24

4.2.1 Getting started with ModusToolbox™24

5 Presence detection solution27

5.1 Radar for presence detection27

5.2 Presence detection application.....27

5.3 Key benefits28

5.4 Key specifications – presence detection solution.....28

5.5 Mounting guidelines and coverage29

5.6 Known limitations and recommendations30

5.7 Known limitations30

5.8 Recommendations31

6 Entrance counter solution32

6.1 Smart entrance counter application32

6.2 Key benefits32

6.3 Key specifications – smart entrance counter solution33

6.4 Mounting guidelines and coverage34

6.5 Known limitations and recommendations35

6.6 Recommendations35

7 Hardware description36

7.1 CYSBSYSKIT-DEV-0136

7.1.1 Baseboard components.....36

7.1.2 Hardware functional description40

7.1.3 CYSBSYS-RP01 module40

7.1.4 PSoC™ 5LP40

7.1.5 Serial interconnection between PSoC™ 5LP and module42

7.1.6 Power supply system42

Important notice

7.1.7	Expansion headers	44
7.1.8	QSPI	44
7.1.9	LED	45
7.1.10	User button.....	45
7.1.11	ECO	45
7.1.12	10-pin SWD/JTAG programming header	46
7.1.13	KitProg3: on-board programmer/debugger	46
7.1.14	Programming and debugging.....	46
7.1.15	USB-UART bridge	47
7.1.16	USB-I2C bridge	47
7.2	XENSIV™ BGT60TR13C wing.....	48
7.2.1	Wing board components.....	48
7.3	Adafruit feather-compatible connectors.....	48
7.3.1	Power supply.....	50
7.3.2	Mechanical buttons.....	50
Appendix A: Hardware design		51
A1.	Schematics	51
A1.1	Sensors	51
A1.2	Adafruit feather-compatible headers.....	52
A1.3	User interface (buttons, LEDs)	52
A1.4	Others	53
B1.	PCB layout	54
C1.	Bill of materials.....	54
Appendix B: Frequently asked questions		57
Revision history.....		58

Table of contents

1 Important notice

Infineon Technologies AG (Infineon) provides the evaluation unit (evaluation kit) titled “connected sensor kit” which is built to enable testing and evaluation of the XENSIV™ KIT CSK BGT60TR13C under the following conditions:

- The evaluation unit is intended to be used for development, TESTING and EVALUATION PURPOSES ONLY and is not considered by Infineon to be a finished end product fit for general consumer use.
- The evaluation unit (not being an end product) is not intended to be complete in various product aspects such as required design, marketing, manufacturing, product safety, security and environmental measures.
- The evaluation unit (evaluation kit) does not fall within the scope of the European Union directives and FCC regulation, and therefore may not meet the technical requirements of these directives or other related directives and regulations.
- The evaluation unit is provided for test and evaluation purposes only to evaluate the XENSIV™ BGT60TR13C radar and XENSIV™ DPS368 sensors. The evaluation unit is provided “as is” without any warranty or liability of any kind.
- The user assumes all responsibility and liability for proper and safe handling of the goods, including following ESD precautions. Further, the user indemnifies Infineon from all claims arising from the handling or use of the goods.
- NEITHER PARTY SHALL BE LIABLE TO THE OTHER PARTY FOR ANY DAMAGES INCLUDING (BUT NOT LIMITED TO) INDIRECT, SPECIAL, INCIDENTAL AND CONSEQUENTIAL DAMAGES.

For additional information, please contact an Infineon application engineer or visit www.infineon.com.

Table of contents

2 Introduction

The XENSIV™ KIT CSK BGT60TR13C supports customers in testing sensor-driven IoT products and radar use cases as well as in prototyping. It offers a real-time sensor evaluation with custom configurations and cloud-based radar-based solution output visualization.

2.1 Kit content

The XENSIV™ KIT CSK BGT60TR13C (Figure 1) comes with:

- Rapid IoT connect developer kit (CYSBSYSKIT-DEV-01) (Figure 2)
- XENSIV™ BGT60TR13C wing (EVAL_BGT60TR13C_Wing) (Figure 3)

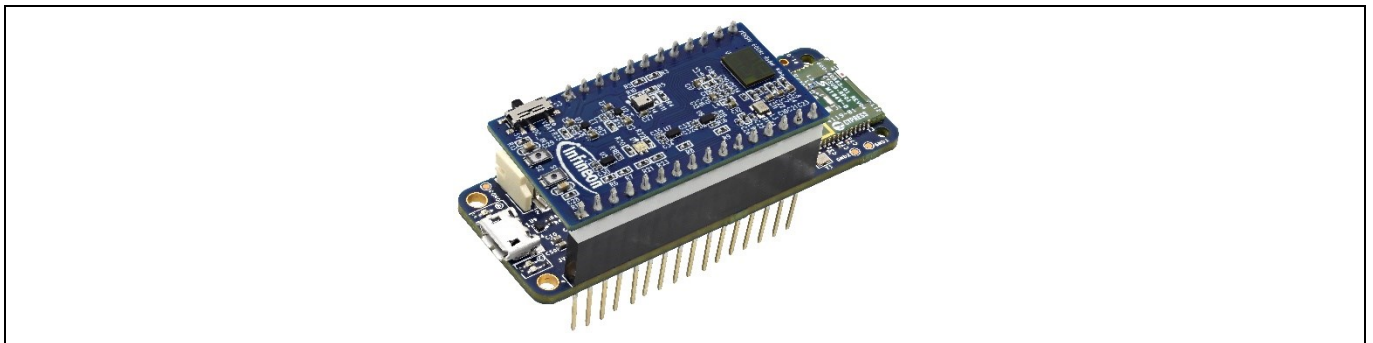

Figure 1 XENSIV™ KIT CSK RADAR

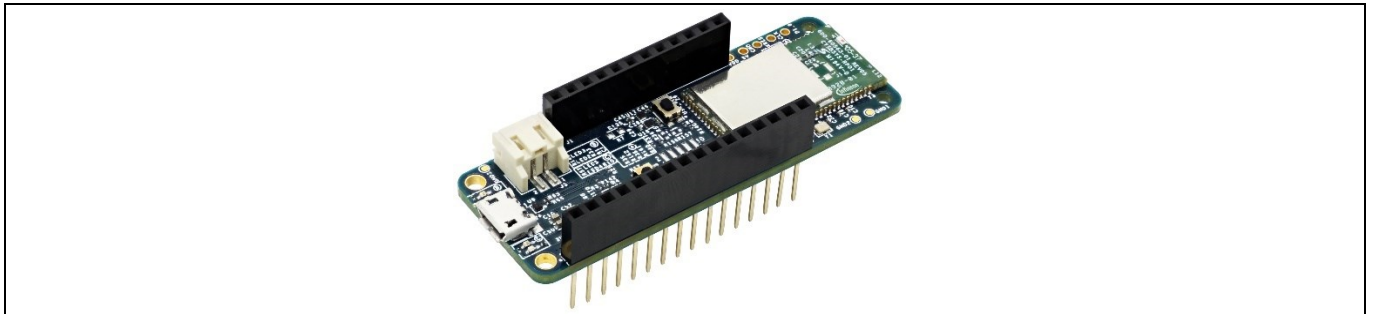

Figure 2 CYSBSYSKIT-DEV-01 rapid IoT connect developer kit

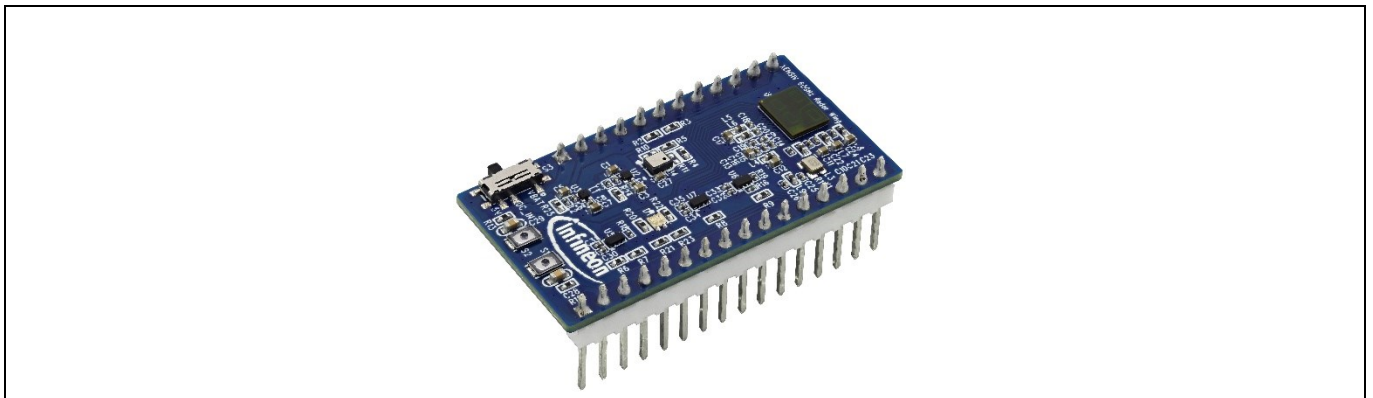

Figure 3 XENSIV™ BGT60TR13C wing

Table of contents

The key component on the wing board is Infineon's XENSIV™ BGT60TR13C radar sensor. It enables ultra-wide bandwidth frequency-modulated continuous-wave (FMCW) operation in a small package that also includes the antennas. Sensor configuration and data acquisition are enabled with a digital interface, and the integrated state machine enables independent data acquisition with power mode optimization for lowest power consumption.

The board also comprises the XENSIV™ DPS368 digital barometric pressure sensor. This high-precision pressure sensor can detect very small changes in barometric pressure, which makes it an ideal device for use cases where accurate pressure event detection is required (e.g., opening of doors or windows, or fall detection).

Having both the radar sensor and pressure sensor on the board gives the possibility to develop and test more complex scenarios where data from both sensors is combined for more reliable event detection.

2.2 CYSBSYSKIT-DEV-01

The Rapid IoT connect developer kit carries a CYSBSYS-RP01 Rapid IoT connect system-on-module (SoM). The Rapid IoT connect SoM includes a PSoC™ 6 MCU device, a CYW43012 single-chip radio, on-board crystals, oscillators, chip antenna, and passive components. The PSoC™ 6 MCU device on the Rapid IoT connect SoM has two cores: Cortex M0+ (CM0+) and Cortex M4 (M4). The firmware running on the PSoC™ 6 MCU can be split into two parts: the application and device management. The device management part runs on the Cortex-M0+ core. The applications part run on the Cortex-M4 core. The Cortex-M0+ core is called the network processor (NP). The Cortex-M4 core is called the customer processor (CP). Resources such as flash, RAM and the peripherals are divided between the NP and CP.

The Rapid IoT connect SoM is the easiest way to provide a secure, scalable, and reliable connection from your device to your cloud. The Rapid IoT connect SoM is a pre-certified 802.11ac-friendly dual-band (2.4 and 5.0 GHz) Wi-Fi and Bluetooth® 5.0-compliant combo radio with an integrated PSoC™ 6 Secure IoT MCU provided in an easy-to-use package. Included within the SoM are the crystals, oscillators, RF switches, passive components, and antenna to help accelerate development of your secure IoT products. It provides up to 51 I/Os in a 26.6 x 14.0 x 2.5-mm castellated surface mount PCB for easy manufacturing.

Along with the Rapid IoT connect developer kit, Infineon® offers the Infineon® Rapid IoT connect cloud platform. This Rapid IoT connect cloud platform allows users to quickly and easily connect their kits to the cloud and see real time sensor data. Rapid IoT connect cloud platform provides several example projects that can be easily programmed onto the user's kit.

The user signs up with the Infineon® Rapid IoT connect cloud platform and registers the Rapid IoT connect developer kit with the unique serial number printed on it. The user chooses an application for evaluation on the Rapid IoT connect developer kit. The Rapid IoT connect cloud platform configures specific application images which are available for download and programming on the Rapid IoT connect developer kit.

Rapid IoT connect cloud platform offers an array of services such as: Firmware over the air (FOTA) updates, device management services such as Location services - parameter monitoring, and much more. Users who desire to use these services for a large number of devices can connect with their respective Infineon® sales support.

2.2.1 CYSBSYSKIT-DEV-01 main components

The Rapid IoT connect developer kit has the following features:

- CYSBSYS-RP01 module
- 512-Mbit external Quad SPI NOR Flash that provides a fast, external expansion memory for data and code
- KitProg3 on-board SWD programmer/debugger, USB-UART, and USB-I2C bridge functionality. KitProg3 is compatible with Mbed OS development flow and is CMSIS-DAP capable.

Table of contents

- A user LED, a user button, and a reset button
- Battery connector, charging IC, and charging indicator LED
- One KitProg3 mode button, one KitProg3 status LED, and one KitProg3 power LED
- **Optiga Trust M** advanced security controller for secure data storage
- Thermistor for sensing the ambient temperature.
- Power supply system consisting of a 3.6V buck-boost regulator with the 1.8V and 3.3V LDO derived from the 3.6V regulator. USB or LiPo battery powers the entire kit.

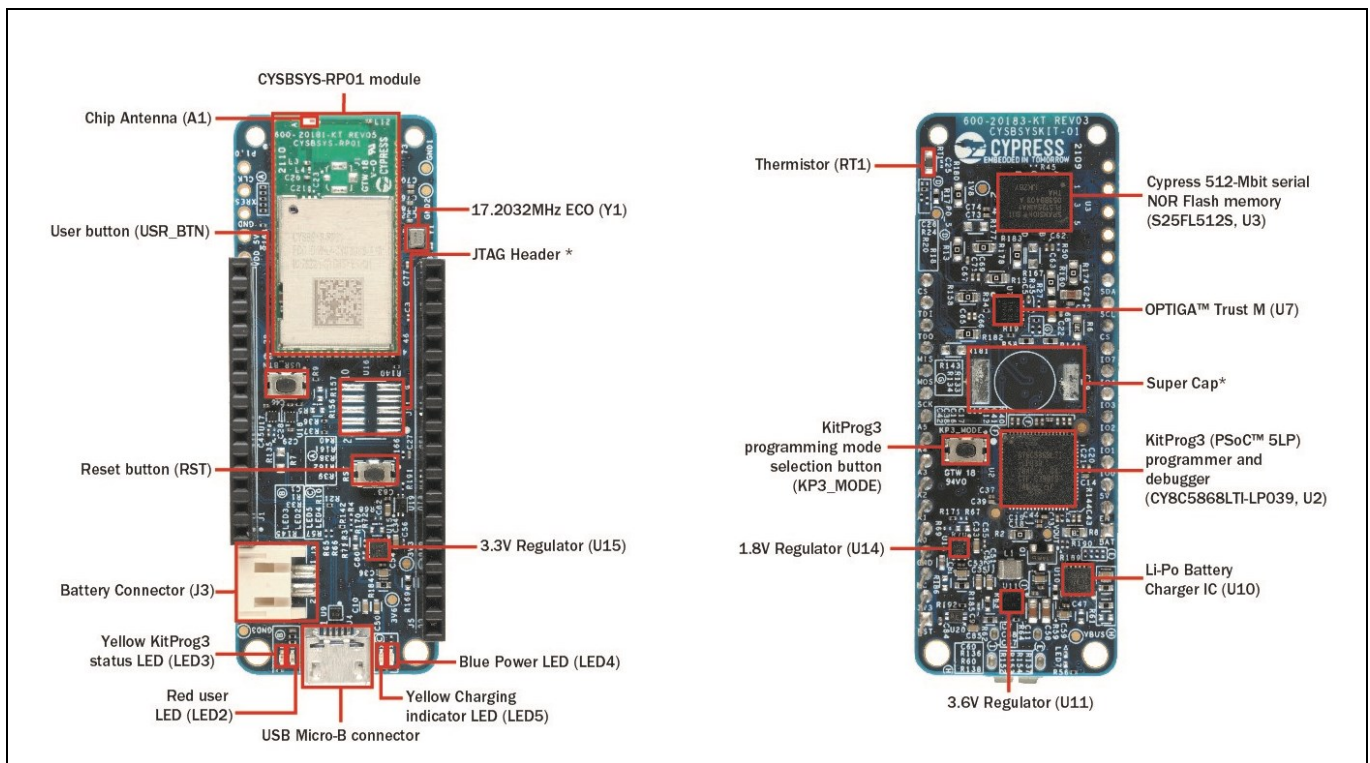

Figure 4 CYSBSYSKIT-DEV-01

2.3 XENSIV™ BGT60TR13C radar

The BGT60TR13C MMIC is a 60GHz radar sensor with integrated antennas and comes with one transmitting and three receiving antennas. Thanks to the L-shaped antenna array, horizontal and as well as vertical angular measurement can be ensured. Moreover, the Antennas in Package (AIP) concept eliminates the antenna design complexity at the user end and the PCB can be designed with standard FR4 materials.

BGT60TR13C MMIC enables ultra-wide bandwidth FMCW operation in a small package (6.5 x 5.0 x 0.9 mm³) and is equipped with an integrated Finite-State Machine (FSM). With the aid of the FSM, BGT60TR13C can perform FMCW frequency sweeps (so-called chirps), data acquisition as well as storing of samples into the internal FIFO memory autonomously. Thanks to optimized power modes during sensor operation, lowest power consumption of <5mW (duty cycle) can be guaranteed. Further reduction of average power consumption will be ensured via DC duty cycling.

Thanks to the ultra-wide bandwidth of 5.5 GHz a very low range resolution down to ~3cm can be offered and in cooperation with a ramp-up speed of 400 MHz/μs a higher doppler velocity achieved. In addition, the high Signal-to-Noise Ratio (SNR) ensures detection of people up to 15 m, front facing towards the sensor, while high

Table of contents

sensitivity allows detection of movements down to sub-millimeter. Via the very commonly used SPI (Serial Peripheral Interface) the host MCU first configures the sensor, then reads the acquired sensor data, and finally performs the application-specific signal processing steps.

2.3.1 Key benefits

- Easy and space-saving integration on FR4 PCB, no external antenna needed
- Three receive antennas to support even complex use cases in the horizontal and vertical angular range
- Detects sub-mm movements (micro-motions)
- SPI for chip configuration and radar data acquisition
- Integrated finite state machine (FSM) for flexible configuration of modulation and power modes

2.3.2 Key features

- 60 GHz radar sensor for FMCW operation
- 5.5 GHz bandwidth
- Antenna-in-package (6.5 mm x 5.0 mm x 0.9 mm)
- Digital interface for chip configuration and radar data acquisition
- Optimized power modes for low-power operation
- Integrated state machine for independent operation

Table of contents

2.4 XENSIV™ DPS368 barometric pressure sensor

The XENSIV™ DPS368 is a miniaturized digital barometric air pressure sensor that is robust against water, dust and humidity. It offers high accuracy and low current consumption and is capable of measuring both pressure and temperature. The pressure sensor element is based on a capacitive sensing principle, which guarantees high precision during temperature changes. The small package makes the XENSIV™ DPS368 ideal for mobile applications and wearable devices. Due to its robustness, it can be used in harsh environments.

2.4.1 Key benefits

- Suitable even for harsh environments
- Easy to integrate and operate; allows fast design-to-market
- High precision makes the DPS368 an ideal device for applications such as fall detection, step counting, door or window opening and environmental scene monitoring in general
- Variety of configurations enables user to choose optimum sensor settings for target application

2.4.2 Key features

- IPx8 certified: temporary immersion of 50 m for 1 hour
- Interface: I²C and SPI (both with optional interrupt)
- Operating modes: command (manual), background (automatic) and standby
- Pressure sensor precision: ± 0.002 hPa (or ± 0.02 m) (high-precision mode)
- Absolute accuracy: ± 1 hPa (or ± 8 m)
- Package dimensions: 8-pin PG-VLGA-8-2, 2.0 mm x 2.5 mm x 1.1 mm

2.5 Board details

The CYSBSYSKIT-DEV-01 rapid IoT connect developer kit serves as the compute and connect part of the CSK. Infineon sensor wing boards, such as the XENSIV™ BGT60TR13C radar wing, sense the environment. The wing board has Adafruit feather-compatible connectors to be stacked individually or combined with other CSK-compatible wing boards on the rapid IoT connect developer kit.

2.5.1 Kit and system block diagram

A block diagram of the wing board is shown in Figure 5. The wing board comprises the XENSIV™ BGT60TR13C radar sensor, the XENSIV™ DPS368 digital pressure sensor and the required power supply components. Power lines are highlighted in red. It is also equipped with push buttons and LEDs.

Table of contents

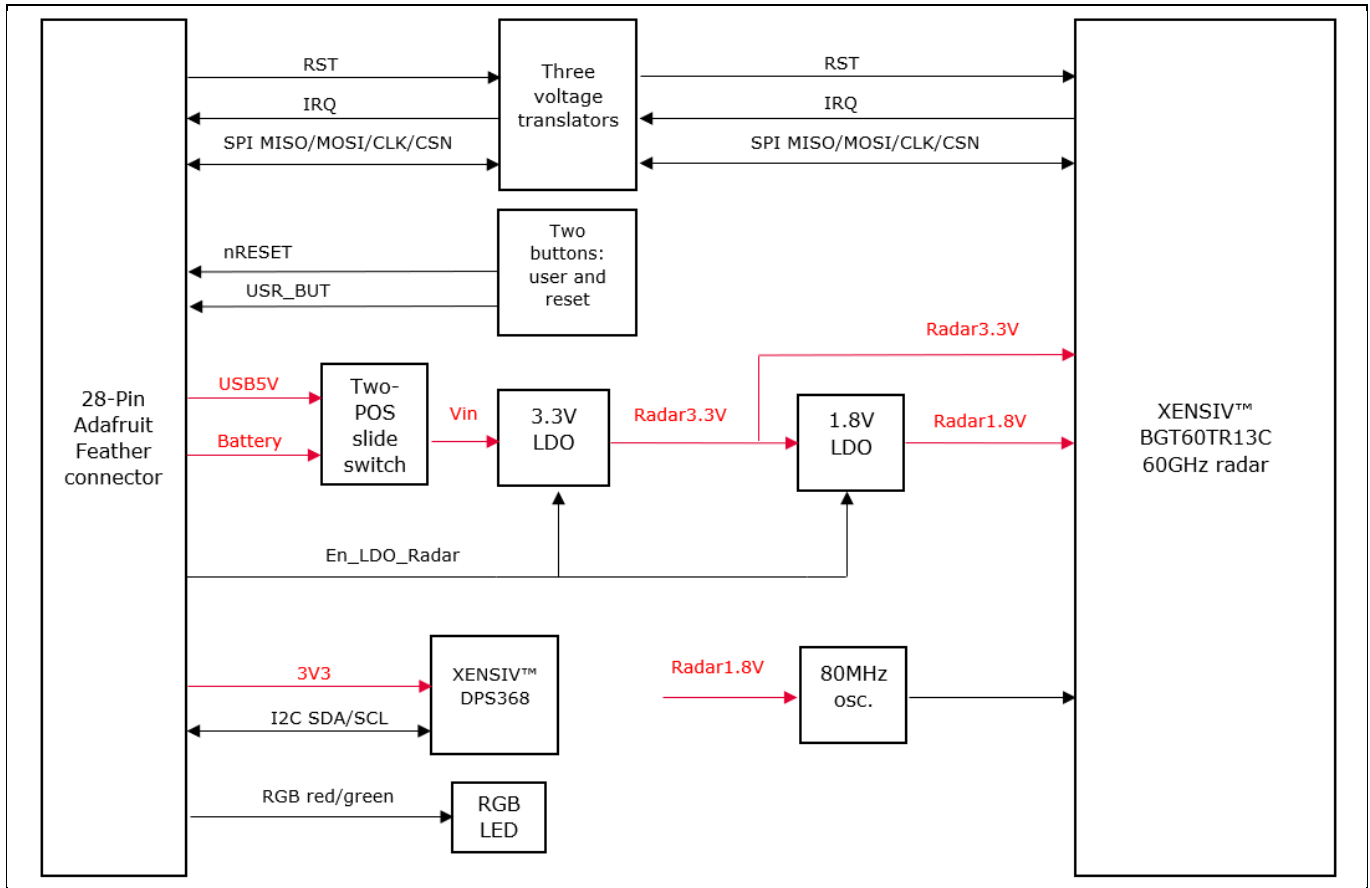

Figure 5 XENSIV™ BGT60TR13C radar wing block diagram

A system block diagram showing the shield connected to the CSK rapid IoT baseboard is depicted in Figure 6. The interface from the shield to the rapid IoT baseboard includes I²C, digital signals, analog signals and power lines. The baseboard can interact with the outside world using Wi-Fi, Bluetooth, USB, or a combination of them depending on the firmware/software (FW/SW) installed on the baseboard. The kit can be powered from an external power supply or from a LiPo battery.

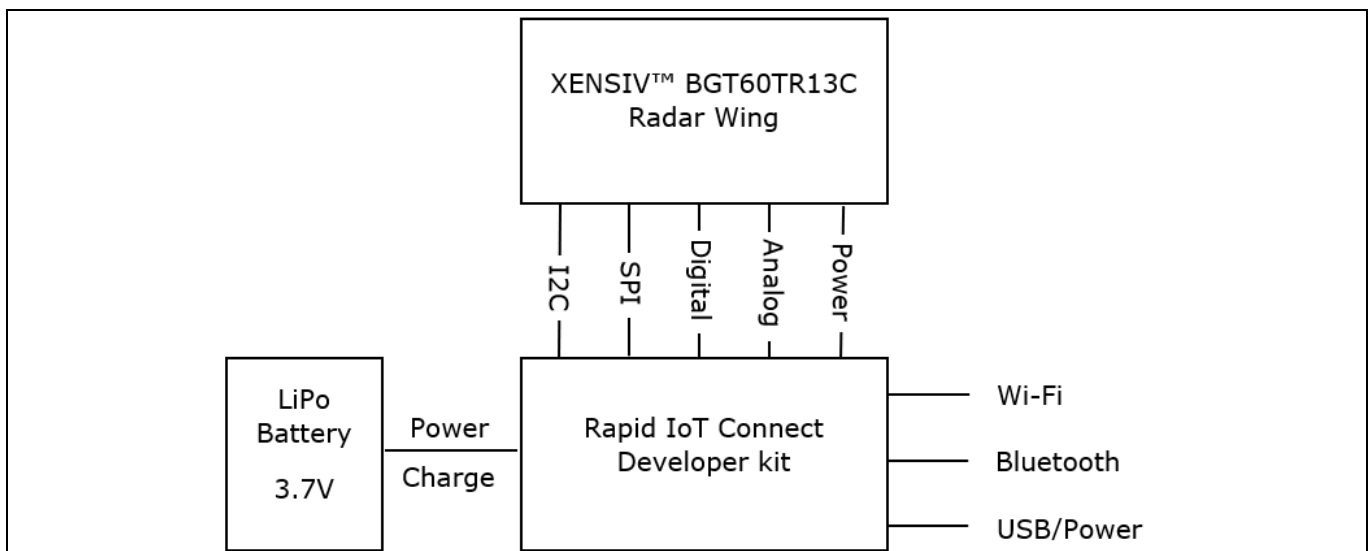

Figure 6 CSK system block diagram

Table of contents

2.6 Getting started

This guide will help you to get acquainted with the XENSIV™ KIT CSK BGT60TR13C:

- Chapter Quick IoT Experience demonstrates how to read sensors and connect to the Rapid IoT connect cloud platform in less the 10 minutes
- Chapter Build your own application explains how to use ModusToolbox™ to build your own application to connect to your own cloud solution. ModusToolbox™ provides numerous code examples to make this process easier.

Note: CYSBSYSKIT-DEV-01 requires ModusToolbox™ 2.2 or higher to design and debug applications. Download and install ModusToolbox™ from www.cypress.com/modustoolbox. See the [ModusToolbox™ Installation Guide](#) and [ModusToolbox™ IDE Quick Start Guide](#) for additional information.

Users can experience the XENSIV™ KIT CSK BGT60TR13C in two ways:

- a) Quick IoT experience for straightforward evaluation
- b) Code examples in ModusToolbox™ for IoT solutions development

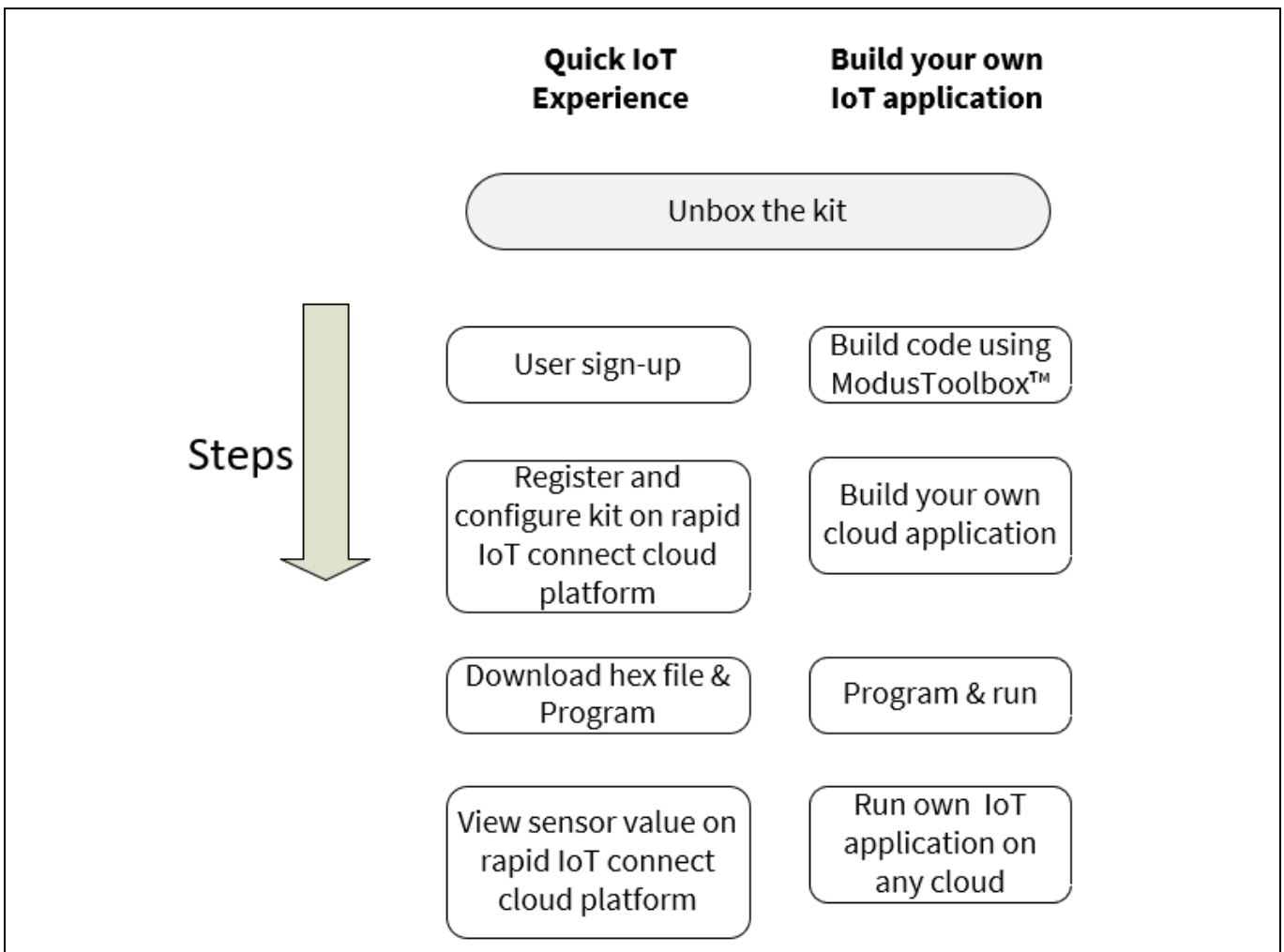

Figure 7 CSK experience steps

Table of contents

2.7 Abbreviations

Table 1 Abbreviations used in this document

Abbreviation	Description
BSP	Board support package
CSK	Connected sensor kit
GPIO	General-purpose input/output
HW	Hardware
I ² C	Inter-integrated circuit
IoT	Internet of Things
LED	Light-emitting diode
PAS	Photoacoustic spectroscopy
PCB	Printed circuit board
PSoC	Programmable system-on-chip
SPI	Serial peripheral interface
UART	Universal asynchronous receiver transmitter

Table of contents

3 Quick IoT Experience

1. **Signup and login:** Create an account with the **Infineon® Rapid IoT connect cloud platform** by signing up with your email address. You will receive the password in your registered email address. You will be prompted to change your password upon your first login to change it to the password of your choice.

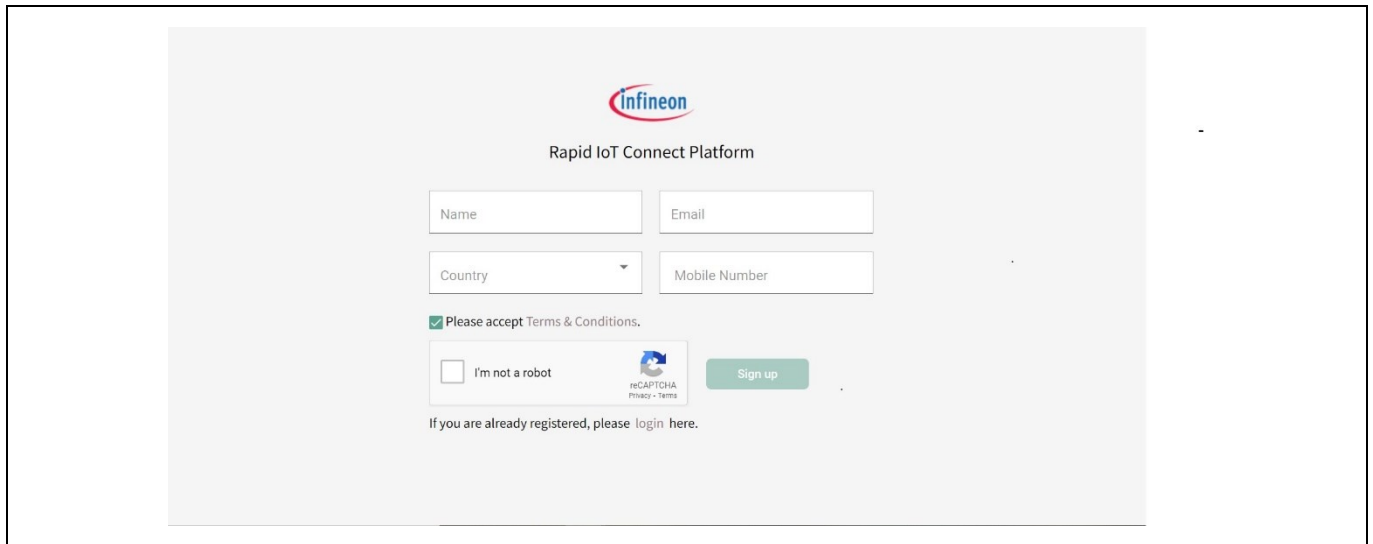

Figure 8 Rapid IoT connect cloud platform sign-up view

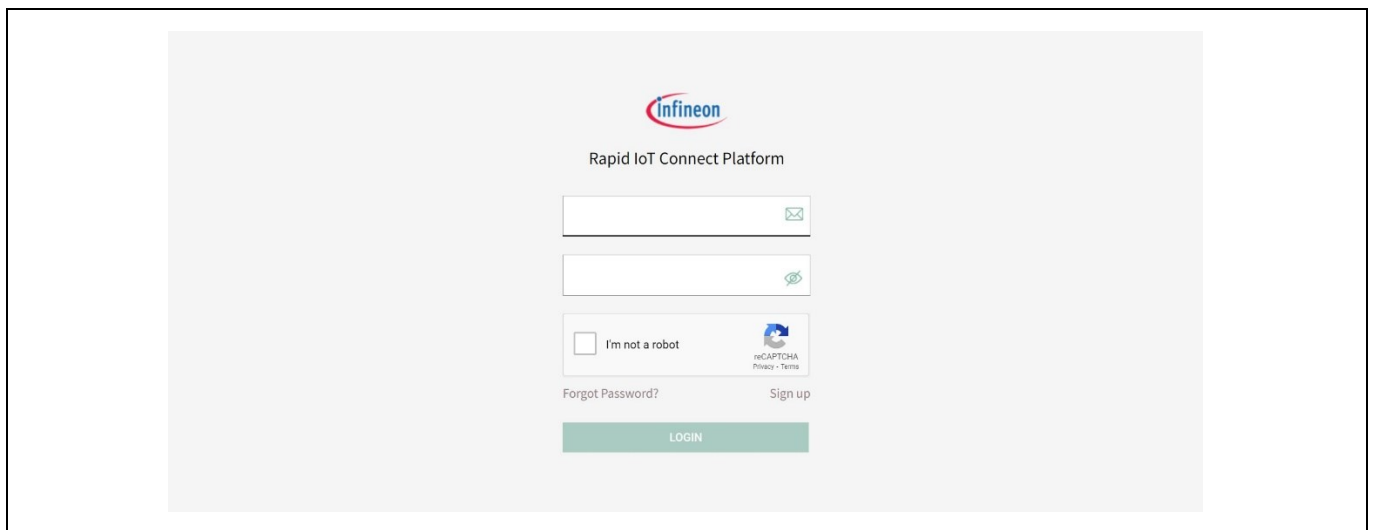

Figure 9 Rapid IoT connect cloud platform login view

2. **Add device:** Click on the “Add device” button to add your new KIT CSK BGT60TR13C. A pop-up wizard will guide you through the process. Provide a name and enter the development kit serial number as shown in the figure and click “Next” button to continue to next screen.

Table of contents

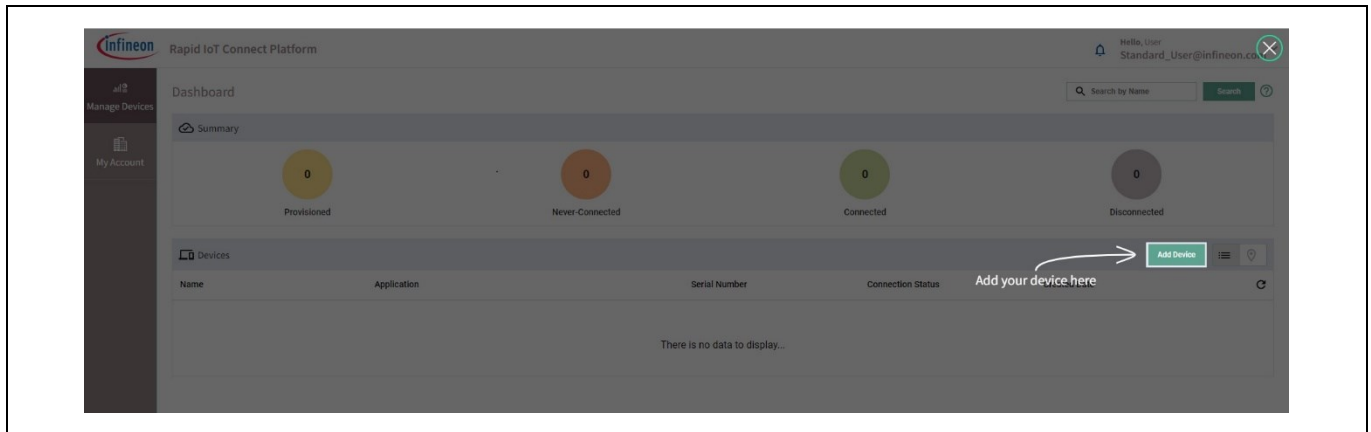

Figure 10 Add device

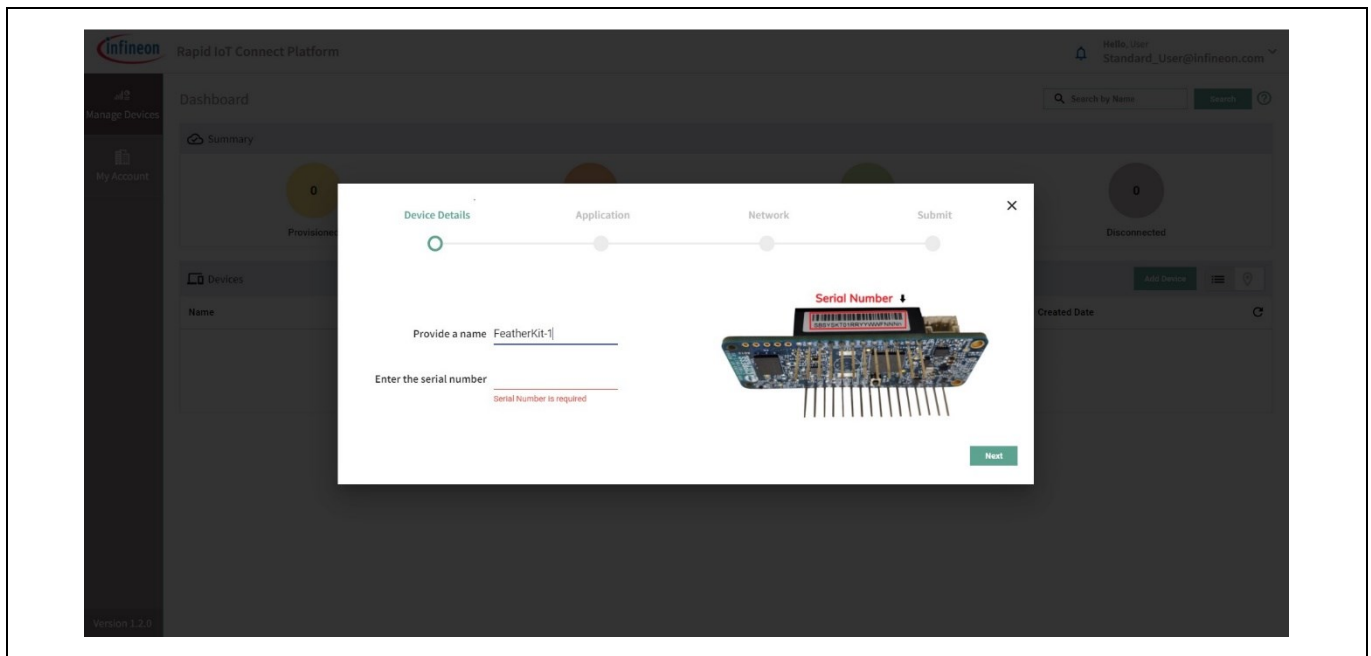

Figure 11 Add device wizard

- Application:** Quick IoT experience will provide a complete IoT sensor experience, in 10 minutes or less, that is inclusive of telemetry and fleet monitoring. After completing this wizard, you will download and program your development kit with a pre-built hex file that prepares and configures the development kit with latest Wi-Fi firmware, an example application, and all the required credentials to securely connect to the cloud. Kindly note that example application will automatically use integrated temperature sensor. Please select your desired application based on the XENSIV wing board present with you, in this case the XENSIV™ BGT60TR13C wing.

Table of contents

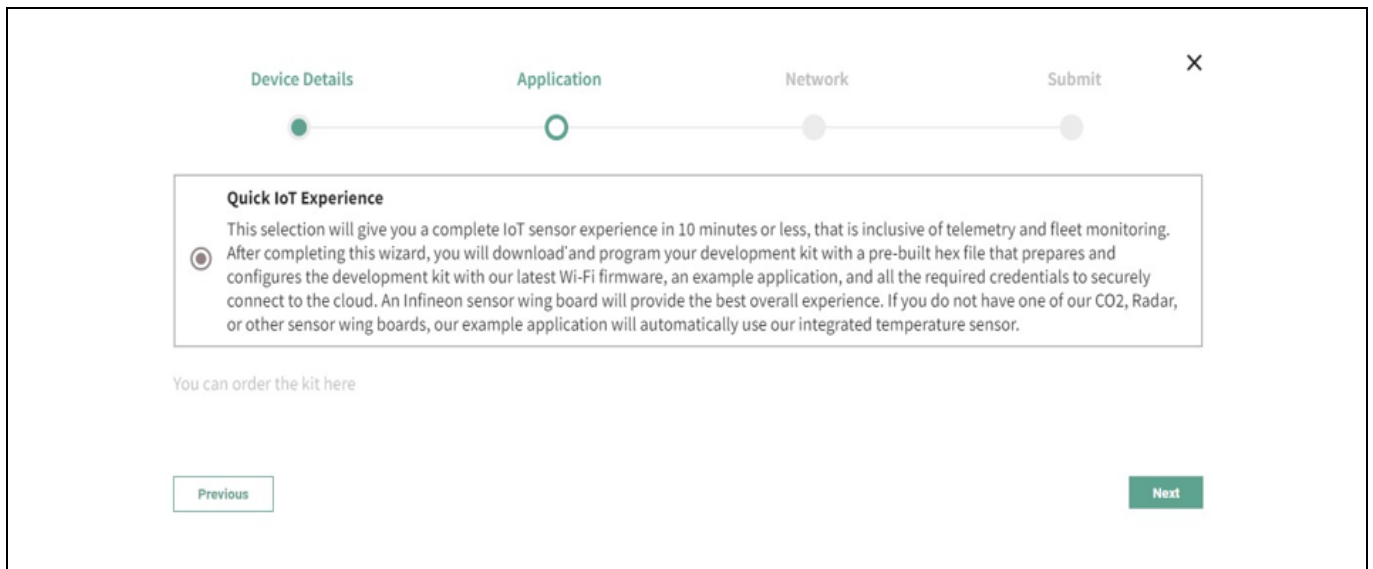

Figure 12 Select application

4. **Configure Wi-Fi network:** You have the option to get the firmware to connect to your preferred WPA2 network by providing the Wi-Fi SSID and password or setup an access point/hotspot of WPA2-PSK security with the following credentials.

SSID: *IFX_Sensor*

Security: *WPA2-PSK*

Password: *S66M14022021*

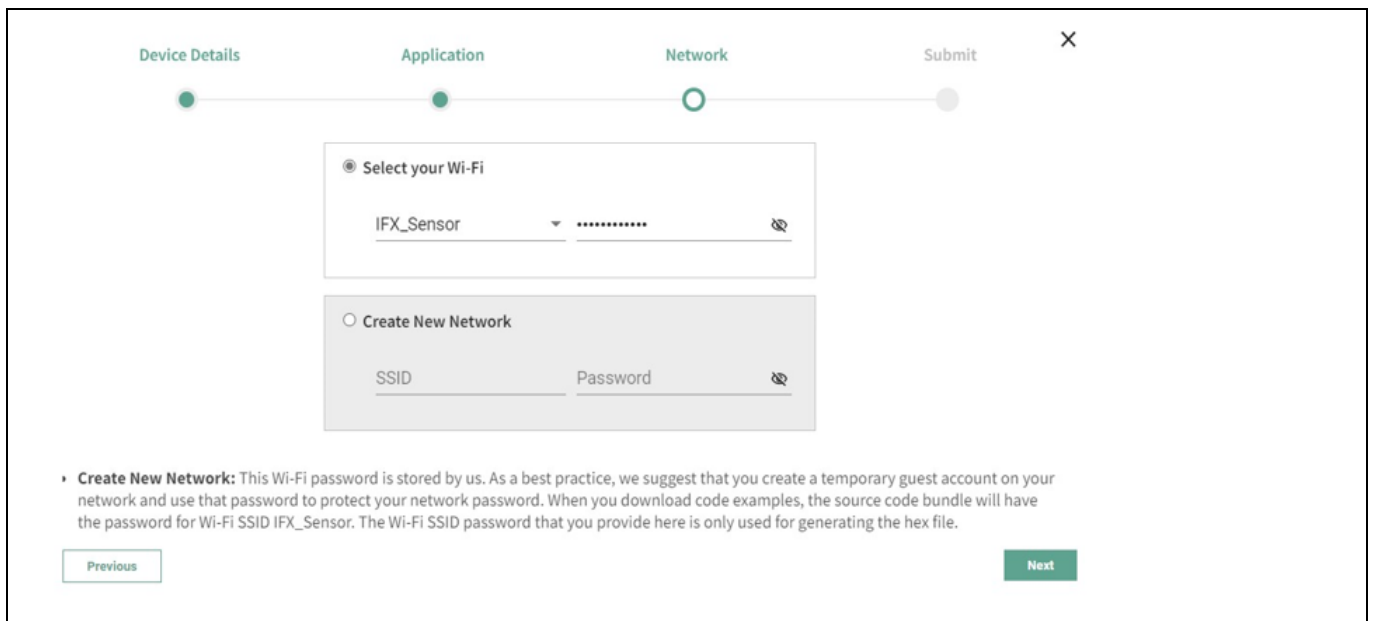

Figure 13 Configure and select network

5. **Submit your device configurations:** Please ensure all the details entered are correct before clicking on the “Submit” button. You can go back to earlier screens by pressing “Previous” if you need to change anything. Once you press “Submit”, a custom hex file is built for your device and a software bundle will be generated to program your development kit.

Note: You can add/register a maximum of 5 devices with Rapid IoT connect cloud platform account.

Table of contents

- 6. **Download the zip package** – Based on your laptop/PC’s operating system (Windows/Linux/Mac), you will be given with a downloadable package containing the firmware image in a hex file and programming tool to program your KIT CSK BGT60TR13C. This will be a zip package. Click on the expand button to view the detailed device status. Please click the download Button next to Success on the application for downloading the zip package.

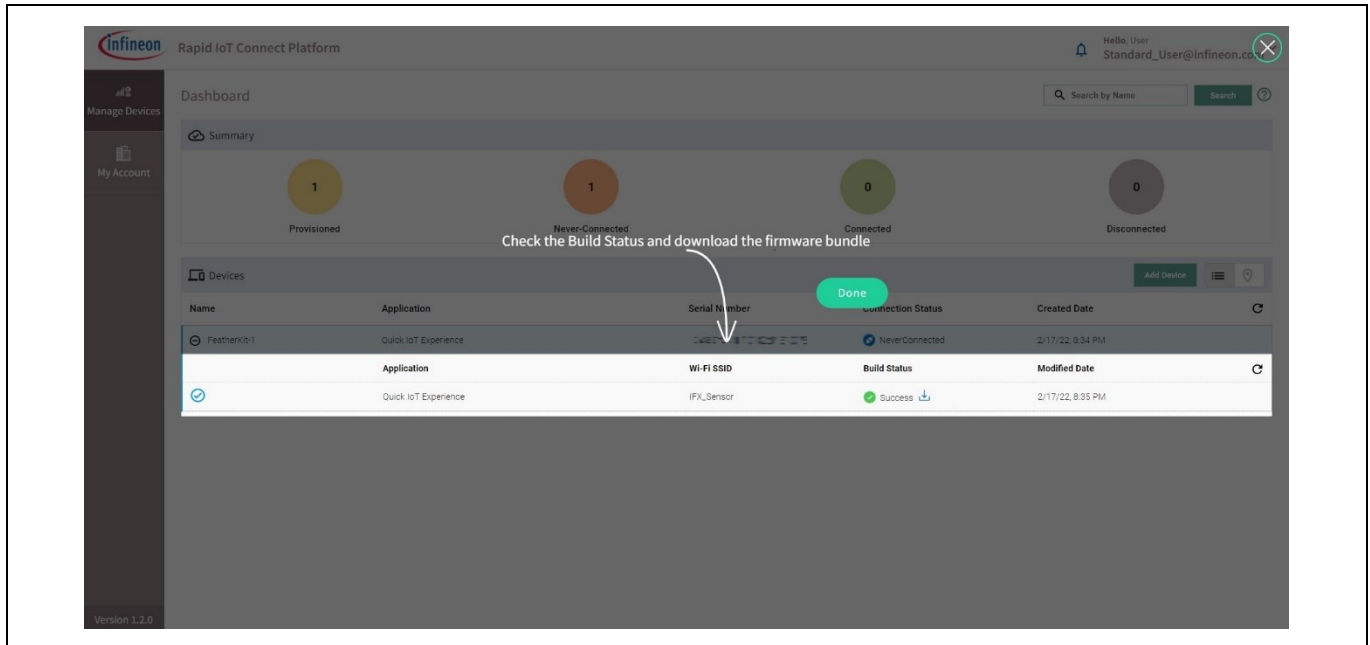

Figure 14 Device management dashboard

- 7. **Program the KIT CSK BGT60TR13C:** Connect your development kit to your PC/laptop using a Micro USB cable. Extract the zip and run the *program_kit* script (*.cmd file for Windows, *.sh for Linux and *.command for Mac). For Linux and MAC users, please ensure that you run the script from a terminal with necessary permissions. Please refer the README for detailed instructions.

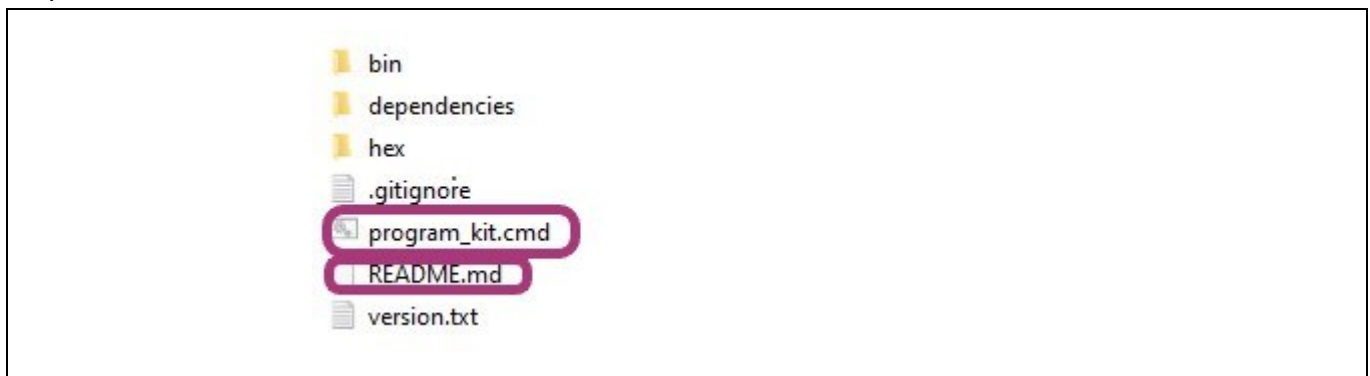



Figure 15 Package contents

Table of contents

8. **Device management:** Manage your device(s) and its configurations from the device management tab. Click on the expand icon  after the **Created Date** to view the respective device details.

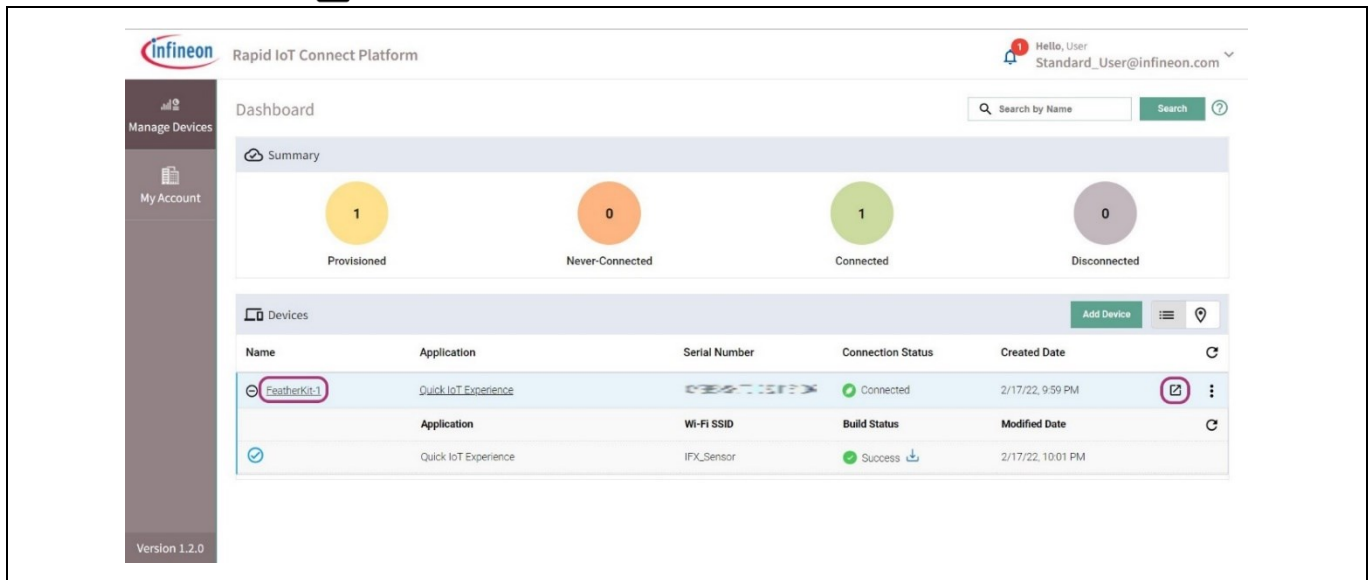

Figure 16 Device connection status

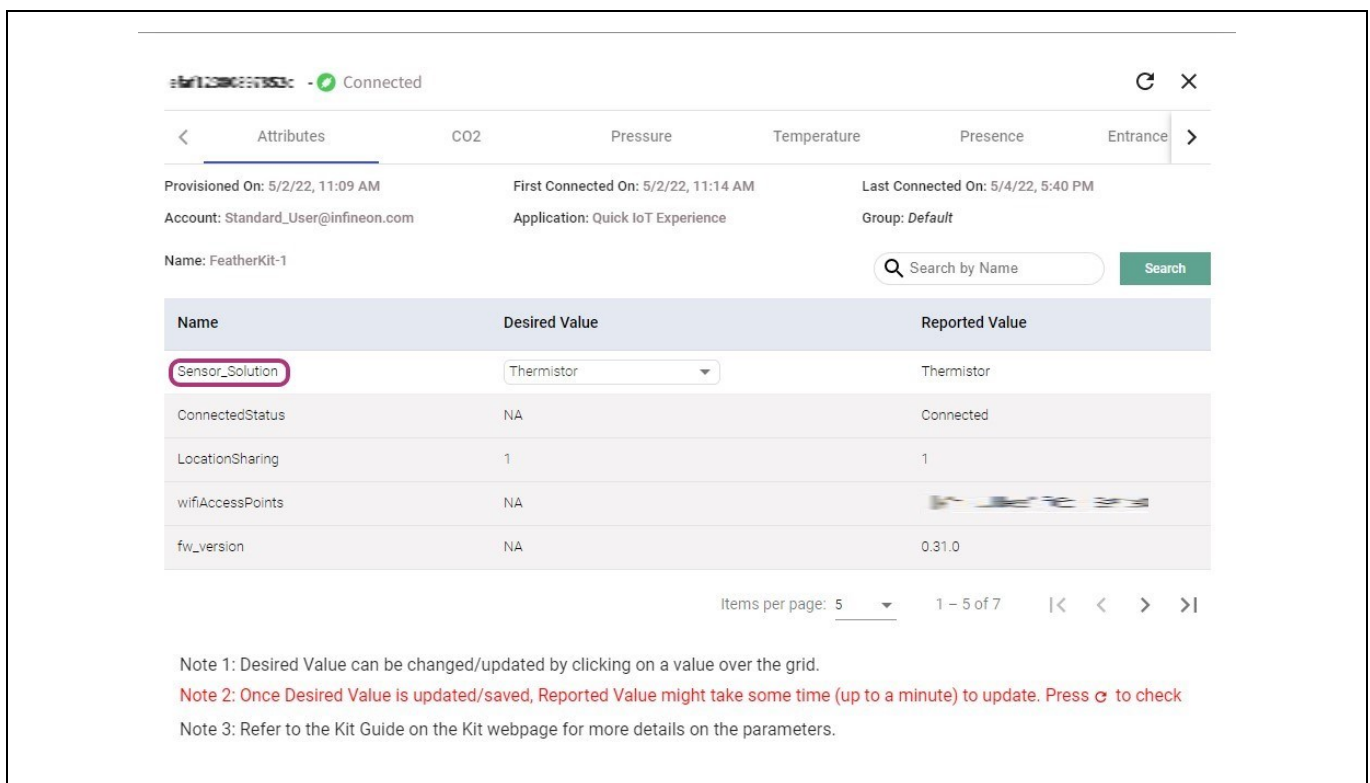

Figure 17 Attributes tabs for connected device

9. **Select desired application:** Select **Attributes** tab on the device details. Click on the dropdown menu for **Sensor_Solution** in the desired value. Please select the desired application based on the connected Infineon® sensor wing board, in our case **XENSIV™ BGT60TR13C wing**. Your application will be set to “Thermistor” as default, since the only sensing element available on CYSBSYSKIT-DEV-01. After the

Table of contents

application is selected, the attributes will be pushed to the device and the device will reboot to the desired application.

Note: The selection of a new application may temporarily cause the connectivity to disconnect and reconnect from the Rapid IoT connect cloud platform.

Please refer Appendix for detailed list of attributes with their definition and possible values.

Table 2 Attributes for Presence application

Attribute	Description
radar_presence_range_max	0.0 – 10.0 Maximum detectable range for presence, in meters. Default value is 2 m.
radar_presence_sensitivity	0.0 – 1.0 Sensitivity for presence detection. Step of 0.1. Default value is 0.5.
kit_mask_level	Disable logs, enable minimal logs or full logs to cloud 60: WARN, MINOR, MAJOR, FATAL all to UART terminal 62: INFO, WARN, MINOR, MAJOR, FATAL all to UART terminal 124: WARN, MINOR, MAJOR, FATAL all to Cloud UI as well as UART terminal

Table 3 Attributes for Entrance Counter application

Attribute	Description
radar_counter_installation	<i>side</i> : side mounting installation <i>ceiling</i> : ceiling mount installation Default is side.
radar_counter_orientation	<i>portrait</i> : radar board is installed at portrait orientation <i>landscape</i> : radar is installed at landscape orientation Default is portrait.
radar_counter_entrance_width	0.0 – 3.0 Entrance width in meters. Default is 1.0.
radar_counter_ceiling_height	1.0 – 3.0 Ceiling height in meters. This parameter is used in ceiling mount installation. Default is 1.0.
radar_counter_min_person_height	0.0 – 2.0 Minimum person height to count, in meters. This parameter is used in ceiling mount installation. Default is 1.0.
radar_counter_traffic_light_zone	0.0 – 1.0 Area where traffic light is red, in meters. This can be used for reminding social distancing purpose. Default is 1.0.
radar_counter_sensitivity	0.0 – 1.0

Table of contents

	Sensitivity for presence detection. Step of 0.1. Default value is 0.5.
kit_mask_level	Disable logs, enable minimal logs or full logs to cloud 60: WARN, MINOR, MAJOR, FATAL all to UART terminal 62: INFO, WARN, MINOR, MAJOR, FATAL all to UART terminal 124: WARN, MINOR, MAJOR, FATAL all to Cloud UI as well as UART terminal
radar_counter_reverse	<i>True</i> : reverse IN/OUT count event <i>False</i> : IN/OUT count event as normal Default value is False.
room_capacity	Capacity of the room in terms of people. Default value is 100. Mimum value is 1.

10. **Change application attributes:** Click on the **Items per page** drop-down menu at the bottom of the **Attributes** tab and change the number of items accordingly so that you can view all attributes in one page. For the Presnece use-case, please refer to the list of attributed in Table 2. For the Entrance Counter use-case, please refer to the list of attributed in Table 3. Additional information can be found in Sections 5 and 6 for respectively Presence and Entrance counter detection.

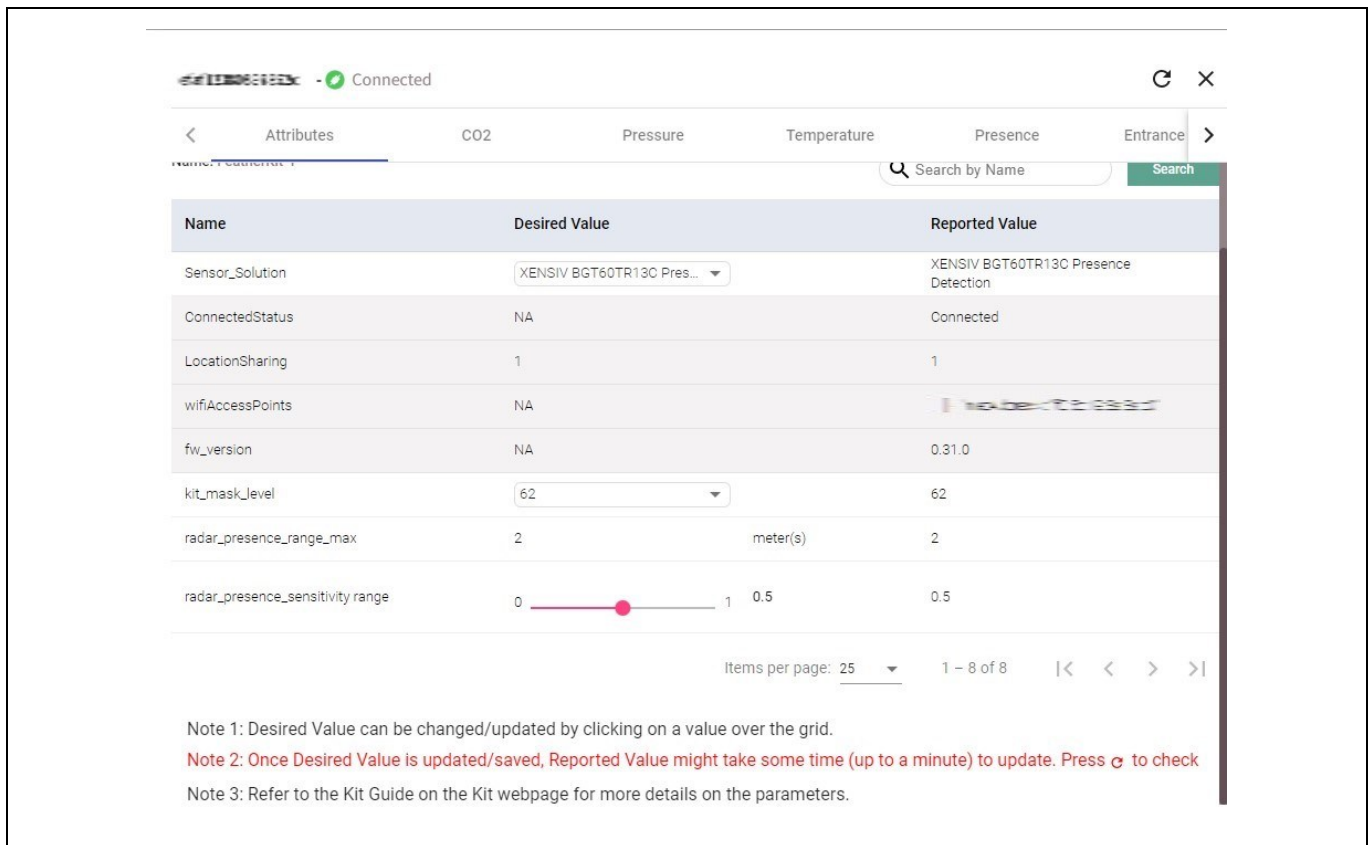

Figure 18 Kit_log level configuration

Table of contents

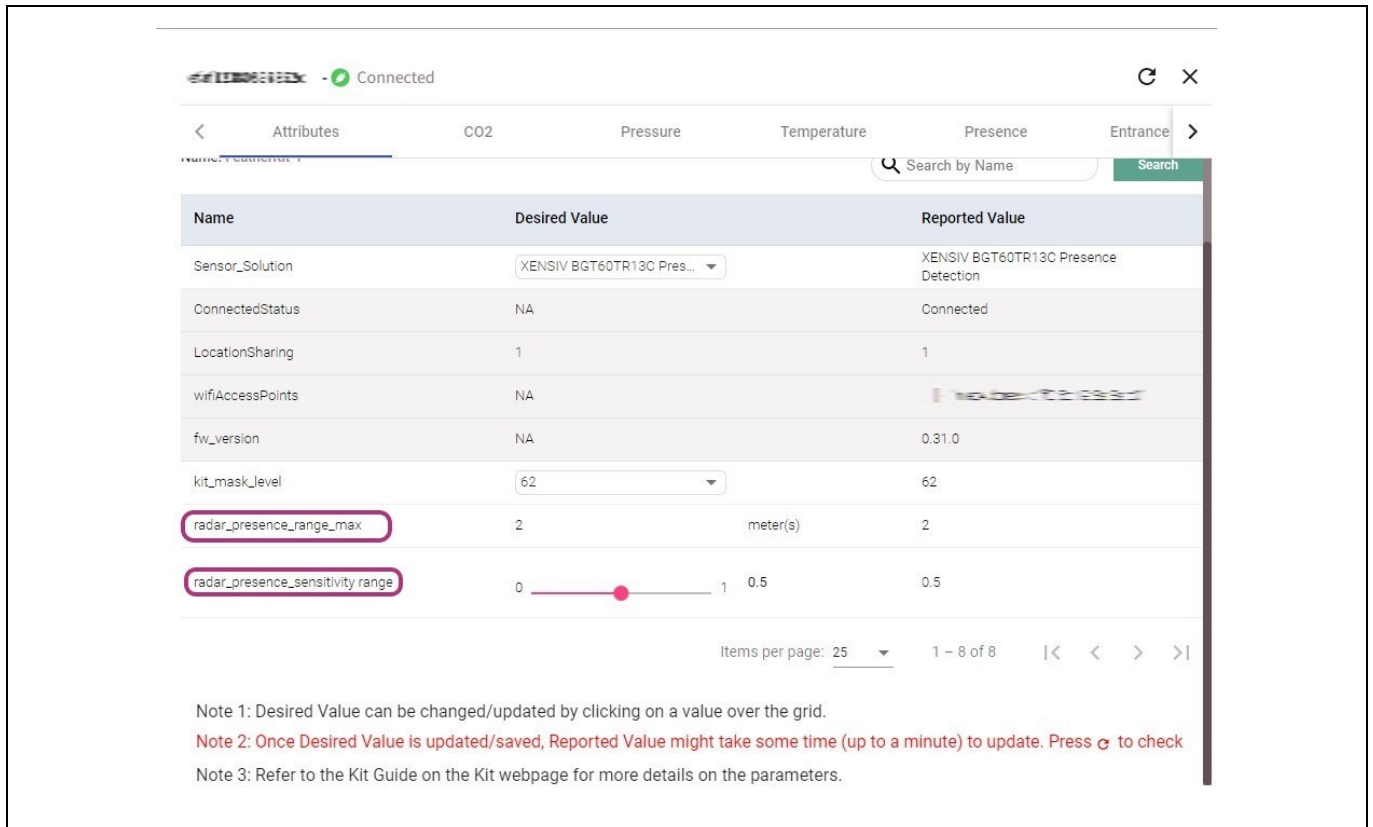

Figure 19 Presence detection attributes

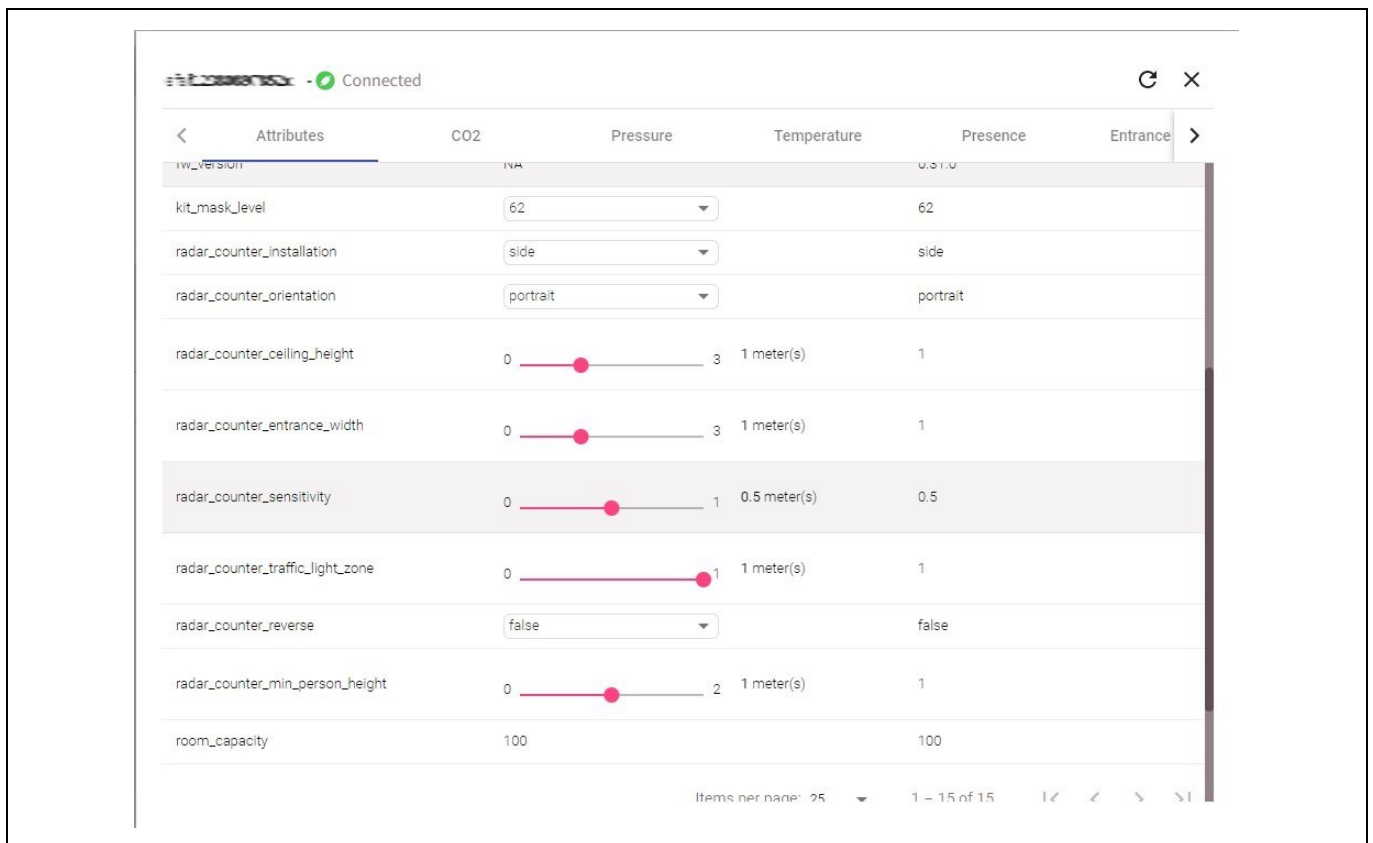

Figure 20 Entrance counter attributes

Table of contents

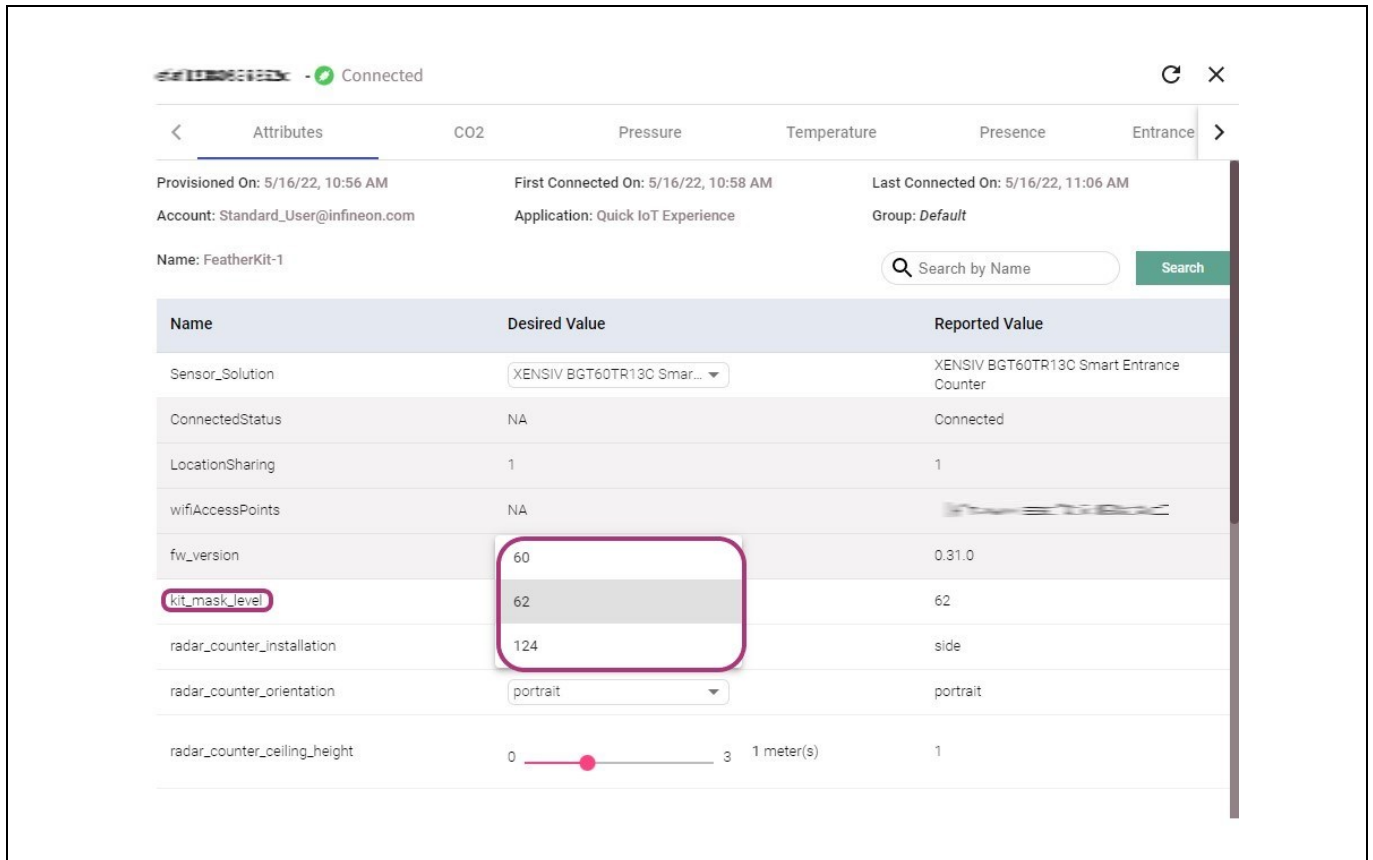

Figure 21 Device log level configuration

View sensor data: Click on the desired tab on the top of the device details window to view your sensor data on the cloud. Please select Presence Detection, Smart Entrance Counter and Pressure if you have Infineon® XENSIV BGT60TR13C wing board. Your application will be set to “Thermistor” as default. Click on the “Presence” or “Entrance Counter” tab to view the data represented as a graph for easy viewing. You can also download the raw data in csv format from the “Download” button on the top right corner.

By default, the data retention period is 14 days for a Standard User. In other words, data recorded more than 14 days ago cannot be retrieved. If you would like to have a data retention period greater than 14 days, please get in contact with us for an upgraded account.

Table of contents

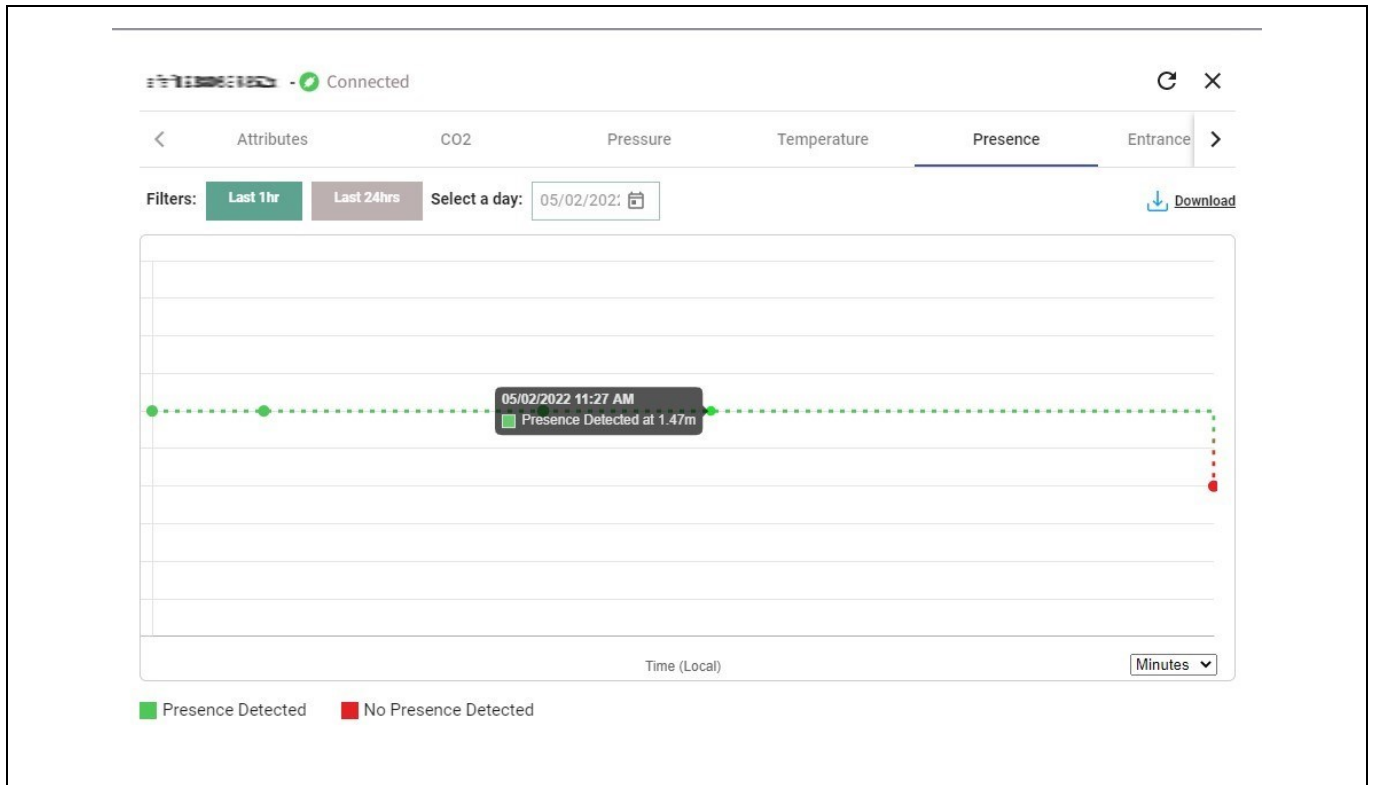

Figure 22 Presence data visualisation: presence detected (detection range is displayed)

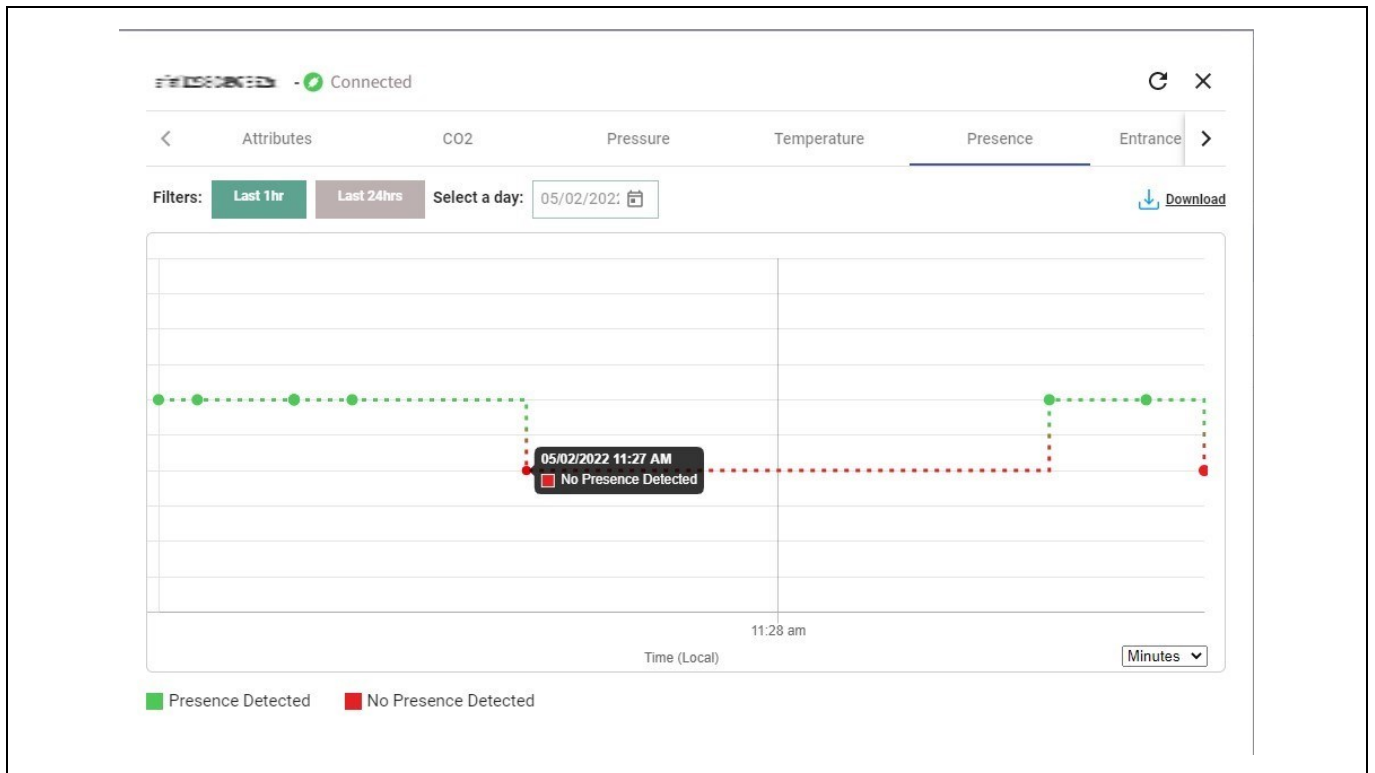

Figure 23 Presence data visualisation: presence is not detected

Table of contents

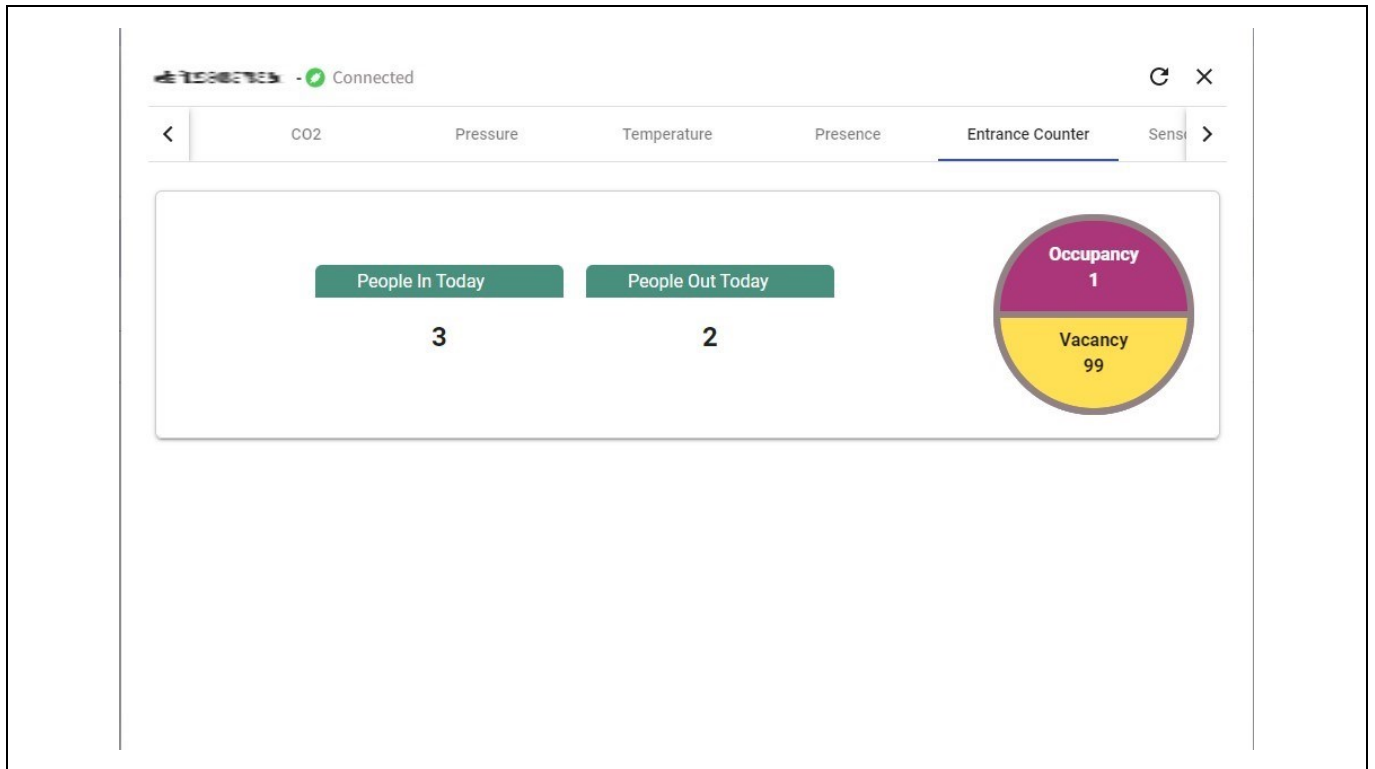

Figure 24 Entrance counter data visualisation

Table of contents

4 Build your own application

The XENSIV™ KIT BGT60TR13C is supported by the [xensiv-radar-sensing](#) and [sensor-xensiv-dps3xx](#) libraries. Code examples using these libraries are available in ModusToolbox™.

4.1.1 XENSIV™ BGT60TR13C radar sensor library

This library provides APIs that enable the user to use existing radar applications such as presence detection, entrance counter or build applications on top. The library uses the ModusToolbox™ HAL interface. Refer to the README.md file for more details.

<https://github.com/Infineon/xensiv-radar-sensing>

4.1.2 XENSIV™ DPS3xx pressure sensor library

This library provides functions for interfacing with the XENSIV™ DPS-310/368 barometric pressure sensors. This library can be set up to use the ModusToolbox™ HAL interface, or user-provided communication functions. Refer to the README.md file for more details.

<https://github.com/Infineon/sensor-xensiv-dps3xx>

Note: The XENSIV™ DPS368 uses the address (0x77) in the XENSIV™ BGT60TR13C radar wing.

4.2 Code examples

The code examples demonstrate presence detection (paragraph 5) and entrance counter (paragraph 6) use cases implemented using the [xensiv-radar-sensing](#) library. Refer to the README.md file for more details.

<https://github.com/Infineon/mtb-example-sensors-radar-entrancecounter>

<https://github.com/Infineon/mtb-example-sensors-radar-presence>

This code example demonstrates implementing an MQTT client using the [MQTT client library](#) for XENSIV™ sensor with Infineon connectivity devices. The library uses the following:

- AWS IoT device SDK MQTT client library that includes an MQTT 3.1.1 client
- xensiv-radar-sensing library allows the user to use existing radar applications such as presence detection, entrance counter or build applications on top

<https://github.com/Infineon/mtb-example-sensors-radar-anycloud-mqtt-client>

4.2.1 Getting started with ModusToolbox™

1. ModusToolbox™ software is a free development ecosystem that includes the ModusToolbox™ IDE. Using ModusToolbox™ IDE, you can enable and configure device resources, middleware libraries, and program and debug the device. You can download the software from the [ModusToolbox™ home page](#). See the ModusToolbox™ user guide for additional information.
2. In the ModusToolbox™ IDE, import the desired code example (application) into a new workspace.
 - Click on New application from quick panel

Table of contents

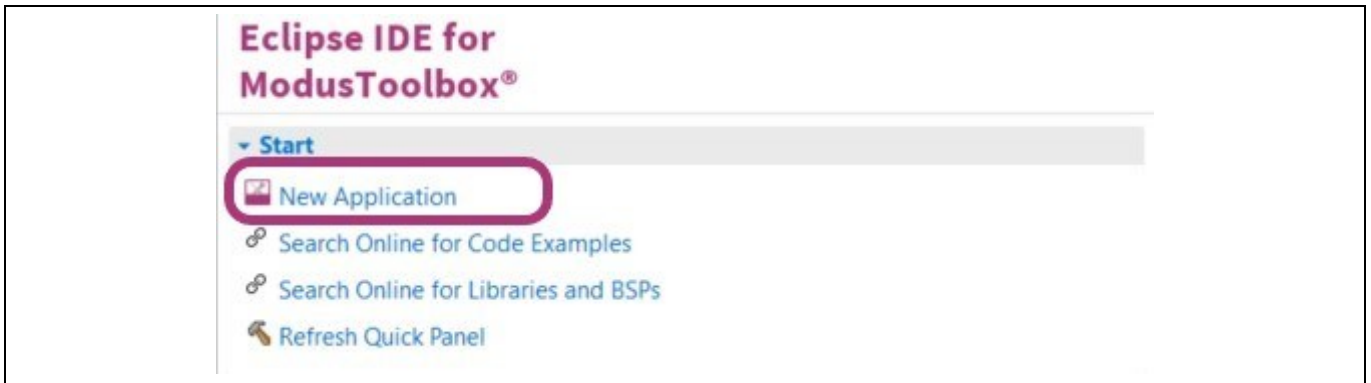

Figure 25 ModusToolbox™ – new application

- Select CYSBSYSKIT-DEV-01 in the choose Board Support Package (BSP) window and click Next, as shown in below figure.

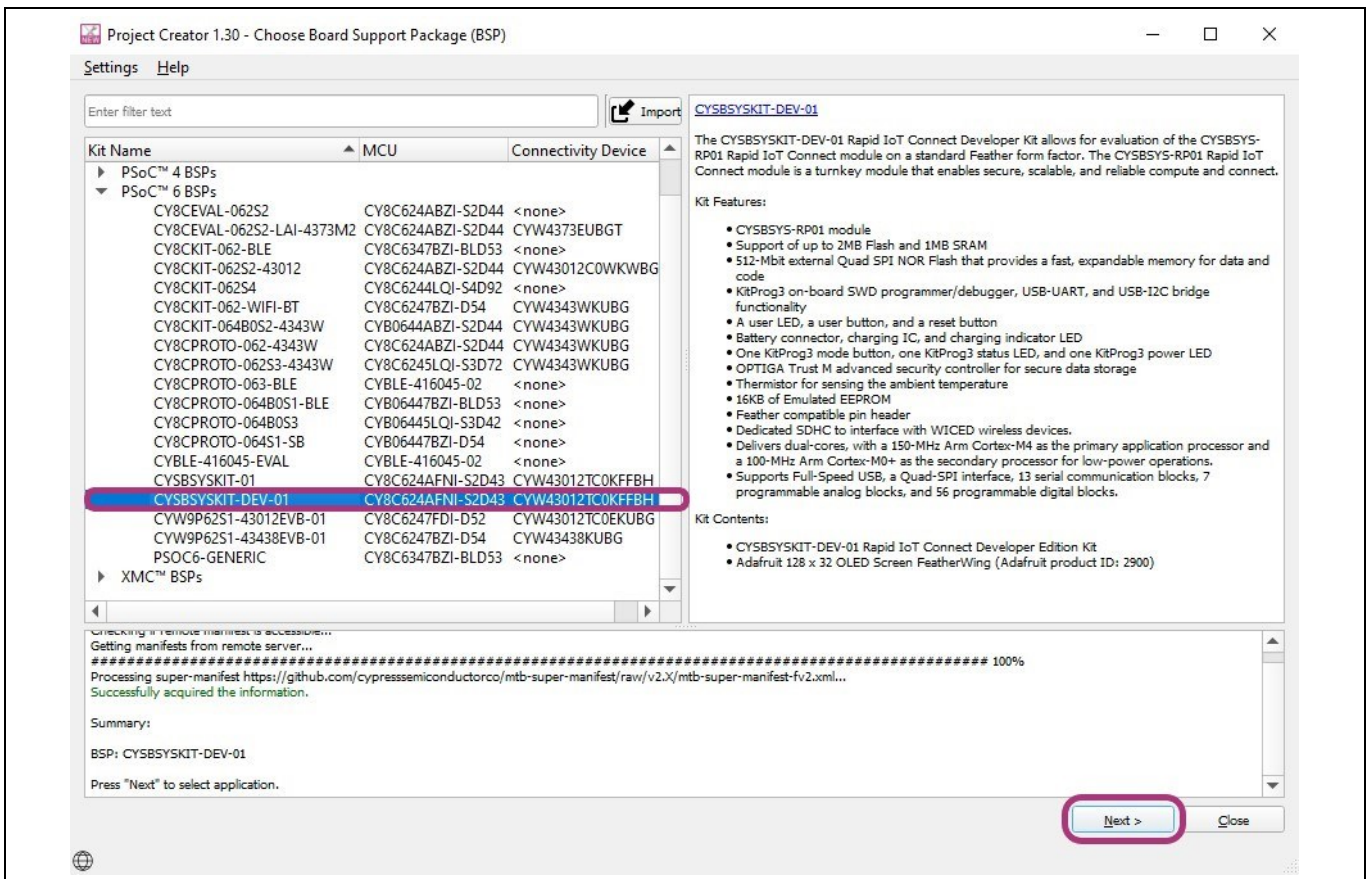

Figure 26 Select development kit

- Select the application and click **Create**, as shown in figure below.

Table of contents

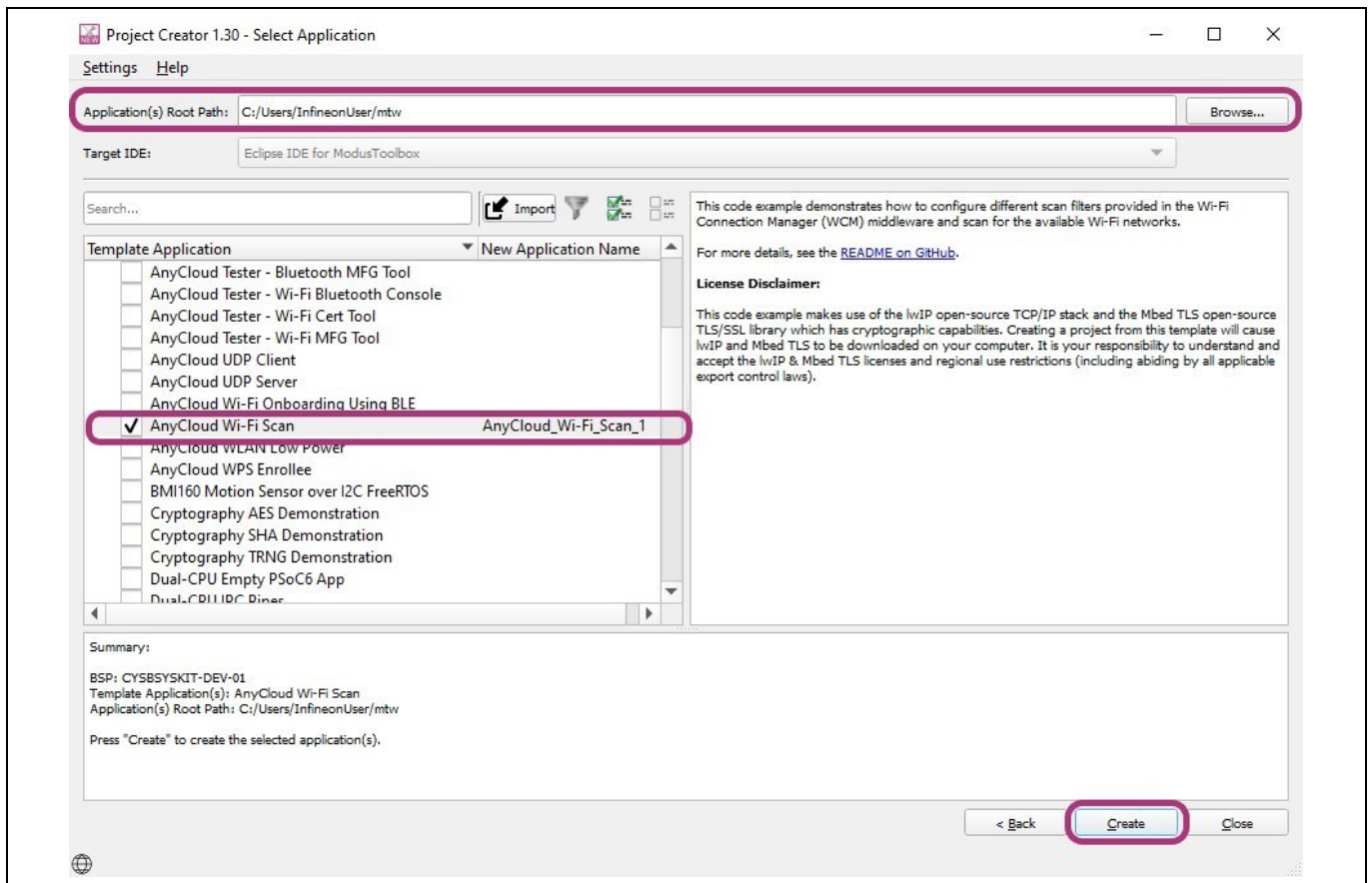

Figure 27 Select ModusToolbox™ application

3. To build and program the application, in the Project Explorer, select project. In the quick panel, scroll to the launches section and click the Program (KitProg3_MiniProg4) configuration.
4. ModusToolbox™ has an integrated debugger. To debug a PSoC™ 6 MCU application, in the Project Explorer, select project. In the quick panel, scroll to the launches section and click the Debug (KitProg3_MiniProg4) configuration.

Table of contents

5 Presence detection solution

The Infineon radar presence detection solution detects both macro- and micro-motions in a configurable range using the XENSIV™ BGT60TR13C radar sensor. This user guide describes the required SW and HW, including how to set up and get started with the Infineon radar presence detection solution using the CSK. Please refer to the CSK user manual for more details on the CSK. Additional documents are available and these are listed at the end of this document.

5.1 Radar for presence detection

Motion sensing is a standard feature in many devices. Today’s devices become smarter by knowing if the user is around or not. Traditionally motion sensors have been designed using passive infrared (PIR) sensing. As simple as PIR is, there are performance limitations. For example, PIR sensors cannot detect small motions when a person is stationary. In addition, they require a lens, while radar sensors can be covered and disguised behind enclosures.

What if there was a solution that could detect the tiniest movements without requiring an opening in the product housing?

Infineon’s radar presence detection solution enables the detection of human presence within a configured range. Enabled by Infineon XENSIV™ BGT60TR13C radar (60 GHz radar, antenna-in-package) with its sophisticated radar presence detection algorithms, this solution provides extremely high accuracy in detecting both macro- and micro-movements.

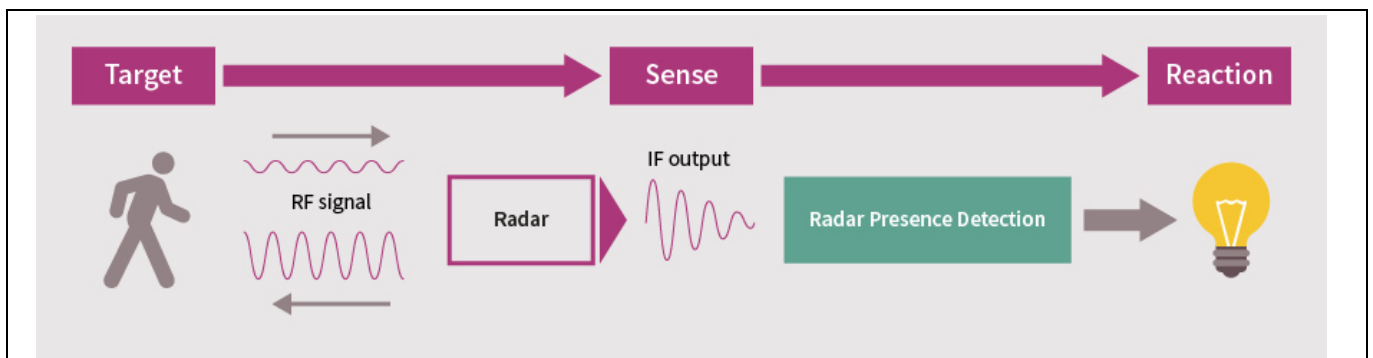

Figure 28 CSK motion detection using 60 GHz radar sensor

5.2 Presence detection application

Presence detection is an application of a radar system, where the radar can detect targets in a specified vicinity. Specifically, the radar detects targets within an angle coverage up to a certain distance. Parameters such as maximum distance can be configured through the radar settings. Presence detection can be further utilized for applications such as keywordless authentication or automatic interaction of smart devices with the user. Figure 29 shows a high-level representation of presence detection.

Infineon’s presence detection algorithm consists of a state machine comprising the following two states:

- Absence state
- Presence state

A state machine is a mathematical model of computation and can be in exactly one of the finite number of states at a given time.

Table of contents

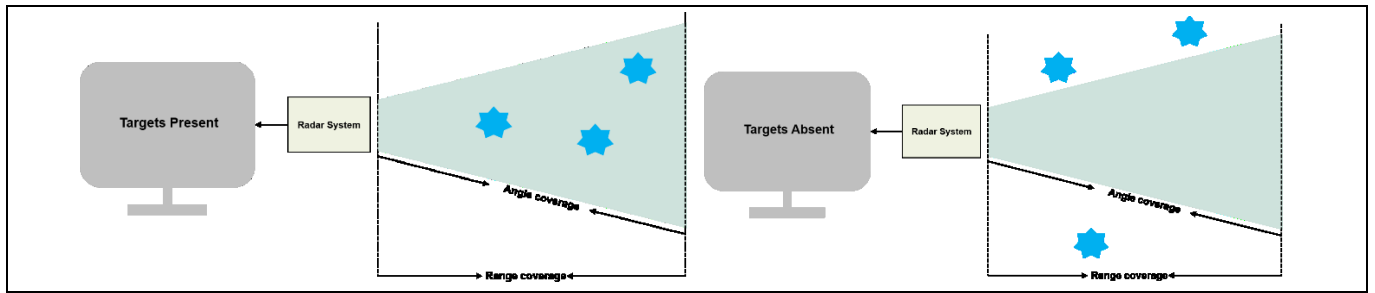

Figure 29 Presence detection principle

5.3 Key benefits

- Ready-to-use radar solution for presence sensing with adjustable detection range and sensitivity
- Ability to detect micro-movements
- Radar sensor immune to environmental factors such as temperature, wind, sunlight and dust/debris
- A fully tested and verified solution for presence sensing for home, office and commercial buildings

5.4 Key specifications – presence detection solution

Moving object size	<ul style="list-style-type: none"> • Detect moving objects with a minimum height of 1 m
Field of view and radar orientation	<ul style="list-style-type: none"> • Azimuth: ± 45 degrees, elevation: ± 40 degrees • Radar chip mounted in front-facing orientation at 1 to 1.5 m height from the floor <p><i>Note: Front-facing orientation example – radar wing board mounted on a wall with radar chip on the top side of the board as shown below.</i></p>
Movement detection range	<ul style="list-style-type: none"> • Maximum supported moving object speed (m/s): 2 m/s • Macro-motion range (regular human movements): minimum: 0.5 m, maximum: less than or equal to 10 m • Micro-motion* detection range: minimum: 0.5 m, maximum: less than or equal to 5 m • Static objects (non-living) are not detected

Table of contents

	<p><i>*Micro-motions: Stationary human (normally breathing and blinking eyes) in sitting or standing positions (in line of sight) with no active movements for at least 30 s – working on laptop/keyboard, reading book, etc.</i></p>
Detection timings	<ul style="list-style-type: none"> • Able to detect presence and absence (less than or equal to 1 s for presence) when at least one moving object is present in the field of view • Declaration of presence/absence states is configurable (time) along with the ability to introduce constant delays (1 to 30 s) before absence state is activated
Configurability	<ul style="list-style-type: none"> • Easy configuration options via radar presence code example using UART port to change various parameters (detection range, sensitivity).
Target platform	<p>CSK comprising:</p> <ul style="list-style-type: none"> • Rapid IoT connect developer kit (CYSBSYSKIT-01): based on PSoC® 6 (ARM® Cortex®-M4F) • XENSIV™ BGT60TR13C radar wing
CPU and memory consumption	<ul style="list-style-type: none"> • CPU: less than 10 percent (target platform), RAM usage: less than 100 kB, Flash: less than 256 kB
HW interface	<ul style="list-style-type: none"> • Presence information is available via UART or GPIO, with optional provision for SPI/I²C as well using radar presence code example
Certifications	<ul style="list-style-type: none"> • Presence solution is FCC certifiable. Recommended radar settings and test report using an embedded reference form factor board could be provided on request.
Test conditions	<ul style="list-style-type: none"> • Radar board mounted at height of 1 to 1.5 m from the ground in front-facing orientation (radar sensor on the top side) • Test subject height ~1.7 m • Ambient temperature: 18 to 24°C • Relative Humidity (RH): 35 to 70 percent
Target applications	<ul style="list-style-type: none"> • Homes, offices, commercial buildings

5.5 Mounting guidelines and coverage

The following mounting guidelines are recommended for the HW unit (radar wing board and rapid IoT connect developer kit) of the CSK:

- Mount it on a wall or tabletop at 1 to 1.5 m height from the ground.
- Unit should be mounted in such a way that the radar wing board is in front-facing orientation (radar chip on top side).
- Ensure that the maximum range parameter is set properly (e.g., set the value lower than the distance to the opposite wall in order to avoid reflection).
- With the above conditions met, below is a representative coverage map created in open space based on around 1.7 m test subject at standard room temperature and humidity conditions.

Table of contents

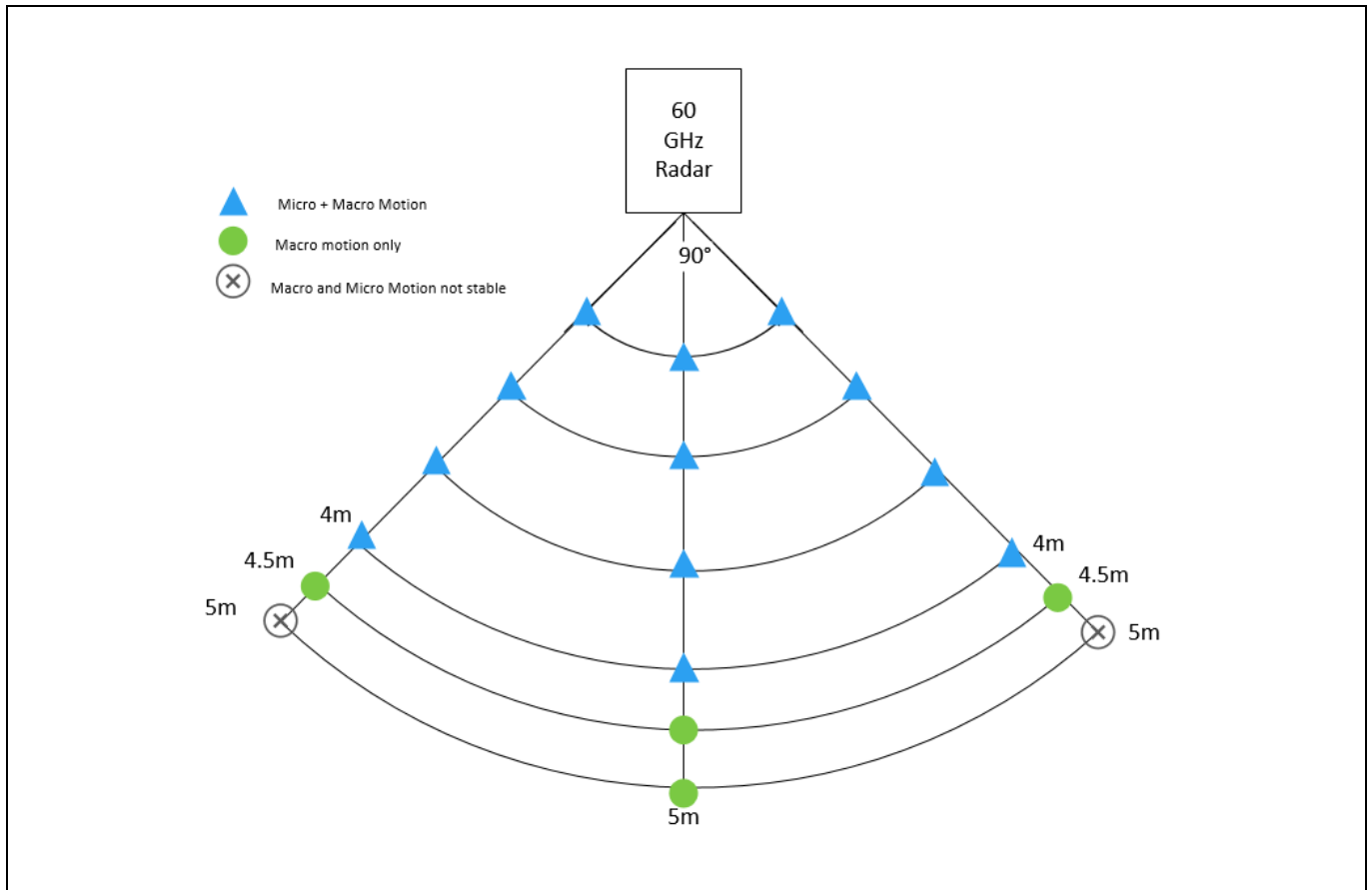

Figure 30 Representative coverage map of radar sensor for certain conditions

5.6 Known limitations and recommendations

5.7 Known limitations

- The presence detection solution is verified using CSK HW as a reference platform. It is provided as part of the CSK offering primarily for evaluation purposes on an “as is” basis (no liability/warranty). The user is responsible for evaluating, adapting and qualifying it as part of their products for their intended applications.
- CSK HW (rapid IoT baseboard, sensor wing boards) is provided as a reference platform (functionally verified but not qualified), enabling functional tests only for development purposes. It is not aimed at supporting qualification tests and reliability assessments.
- The current verification is done for front-facing wall-mount configuration, HW mounted (vertical orientation with radar sensor on top side) at a height so that it covers the torso area of most adults. It is recommended to mount the radar board at a height of 1.1 to 1.4 m for the best results.
- The presence detection application provides primarily “presence” or “absence” outputs when at least one person is there within the active zone (+/- 45-degree azimuth, +/- 40-degree elevation, up to configured range) for front-facing radar orientation. It doesn’t yet support segmentation, angle data, people counting and positioning information.
- The current solution detects presence in case of motion irrespective of the type of moving objects (e.g., humans, pets, service robots, etc.).

Table of contents

- The maximum range parameter can be set up to 10 m. However, verification testing has been done primarily for a maximum range of 5 m.
- The detection range might reduce at angles depending on the sensitivity setting being used. For example, with the default settings using medium sensitivity at [+45 degrees, -45 degrees], macro-movement detection range might reduce to 4 to 4.5 m, whereas micro-movement detection range might reduce to 3.5 to 4.0 m. Higher-sensitivity settings help in achieving longer ranges at angles.
- Elimination of target detection through the wall is not supported in this release.
- The solution is not designed/optimized for presence detection through glass walls.

5.8 Recommendations

- It is recommended to set the maximum range parameter based on the room size. The user should avoid setting longer ranges for smaller rooms (e.g., 5 m maximum range for a room length of 3 m), as it might result in false presence detection caused by multiple reflections.
- The solution might react to certain moving conditions (e.g., moving curtains, plant movements, facing a wall within its active zone, etc.) so, for the time being, the user is recommended to either install it in a location where such conditions can be avoided, or adapt the maximum range accordingly.
- For optimal results, the user is recommended not to install a reference HW board in corners where the radar chip is facing a side wall, to avoid multiple reflections.

Table of contents

6 Entrance counter solution

A smart entrance counter solution (SECS) counts the number of people entering and exiting premises such as supermarkets, pharmacies, office buildings, etc. It helps the business owners to determine the occupancy of their premises, enabling various solutions such as maintaining social distancing inside the premises, evacuating during an emergency and saving energy based on occupancy. The entrance counting data can be sent to a centralized server, so many sensors can be interconnected. In addition, the statistics collected by the central server can be displayed remotely on a laptop or mobile device to understand the occupancy level of the facility. This user guide describes the required SW and HW, including how to set up and get started with Infineon SECS using CSK. Please refer to the CSK user manual for more details about CSK. Additional documents are available and are listed at the end of this document.

6.1 Smart entrance counter application

Infineon’s SECS counts the (real-time) number of people entering and/or exiting. Enabled by Infineon’s XENSIV™ BGT60TR13C radar sensor with its sophisticated radar entrance counting algorithm, this solution provides highly accurate counting without delay. The current solution has been developed for people entering or exiting one after another (one at a time).

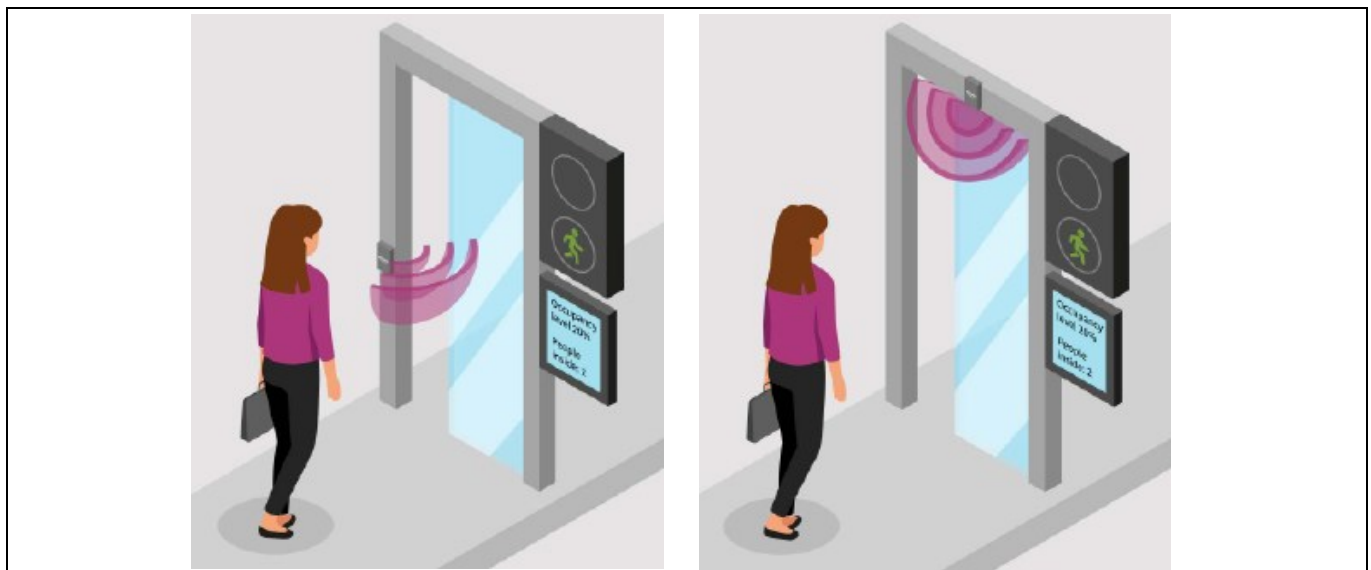

Figure 31 Radar mounted on the side of the door (left) and at the top of the door (right)

6.2 Key benefits

- Ready-to-use radar solution for entrance counting with adjustable detection range
- Bidirectional counting – one sensor per entrance
- Indicate stop sign for the second person on the dashboard for maintaining social distancing*
- Radar sensor immune to environmental factors such as temperature, wind, sunlight and dust/debris
- Fully General Data Protection Regulation (GDPR) compliant
- A well-tested and verified solution for entrance counting for retail, office and commercial buildings

Table of contents

6.3 Key specifications – smart entrance counter solution

Title	Description
Moving object size	<ul style="list-style-type: none"> Detect moving objects with a minimum height of 1 m
Field of view and radar orientation	<ul style="list-style-type: none"> Detection range: up to 3 m Azimuth: ± 45 degrees, elevation: ± 40 degrees Radar chip mounted in front-facing orientation at 1 to 1.5 m height from the ground <p><i>Note: Front-facing orientation example – radar wing board mounted on a wall with radar chip on the top side of the board as shown below)</i></p> 
Walking speed	<ul style="list-style-type: none"> Maximum supported moving object speed (m/s): 2 m/s
Detection timings	<ul style="list-style-type: none"> Able to detect people going in or out (one person at a time) of the entrance area in real time (less than or equal to 1 s)
Configurability	<ul style="list-style-type: none"> Easy configuration options using radar entrance counter code example using UART port to change various parameters (detection range, sensitivity, etc.)
Target platform	<p>CSK comprising:</p> <ul style="list-style-type: none"> Rapid IoT connect developer kit (CYSBSYSKIT-01): based on PSoC® 6 (ARM® Cortex®-M4F) XENSIV™ BGT60TR13C radar wing
CPU and memory consumption	<ul style="list-style-type: none"> CPU: ~25 percent (target platform), RAM usage: less than 125 kB, Flash: less than 256 kB
HW interface	<ul style="list-style-type: none"> Count data is available via UART or GPIO, with optional provision for SPI/I²C as well using radar entrance counter code example
Certifications	<ul style="list-style-type: none"> SECS is FCC certifiable. Recommended radar settings and test report on using an embedded reference form factor board can be provided on request.
Test conditions	<ul style="list-style-type: none"> Radar chip mounted above the door at the entrance or mounted on the side of the entrance passage Test subject height ~1.7 m

Table of contents

Title	Description
	<ul style="list-style-type: none"> Ambient temperature: 18 to 24°C Relative Humidity (RH): 35 to 70 percent
Target applications	<ul style="list-style-type: none"> Homes, offices, commercial buildings

6.4 Mounting guidelines and coverage

- The following mounting guidelines are recommended for the HW unit (radar wing board and rapid IoT baseboard) of the CSK:

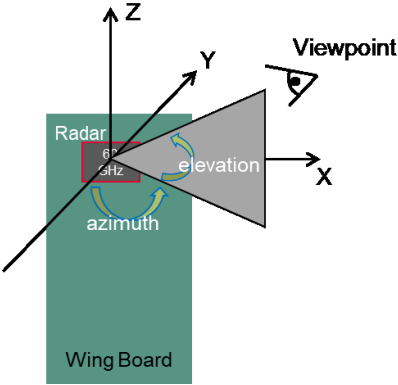
Attention: Make sure there are no moving objects or swinging doors in the field of view of the radar!

- Top/ceiling mount:
 - Mounted at a height of up to 3 m from the ground; sensor board longer edge is perpendicular to the passage.
 - It is recommended to limit the maximum range of the solution to the height of the sensor board from the ground for good performance.
- Side mount:
 - Portrait orientation at around 1.1 to 1.5 m on a wall/door/pillar in such a way that the radar sensor (on the top side of the board) is facing the entry/exit passage from the side for people counting.
 - For side mounting, it is recommended to set the maximum range parameter based on the width of the entrance in such a way that it is less than the distance of the sensor to the wall (if there is one).
- Field of view (FoV) is shown in Figure 32, below.

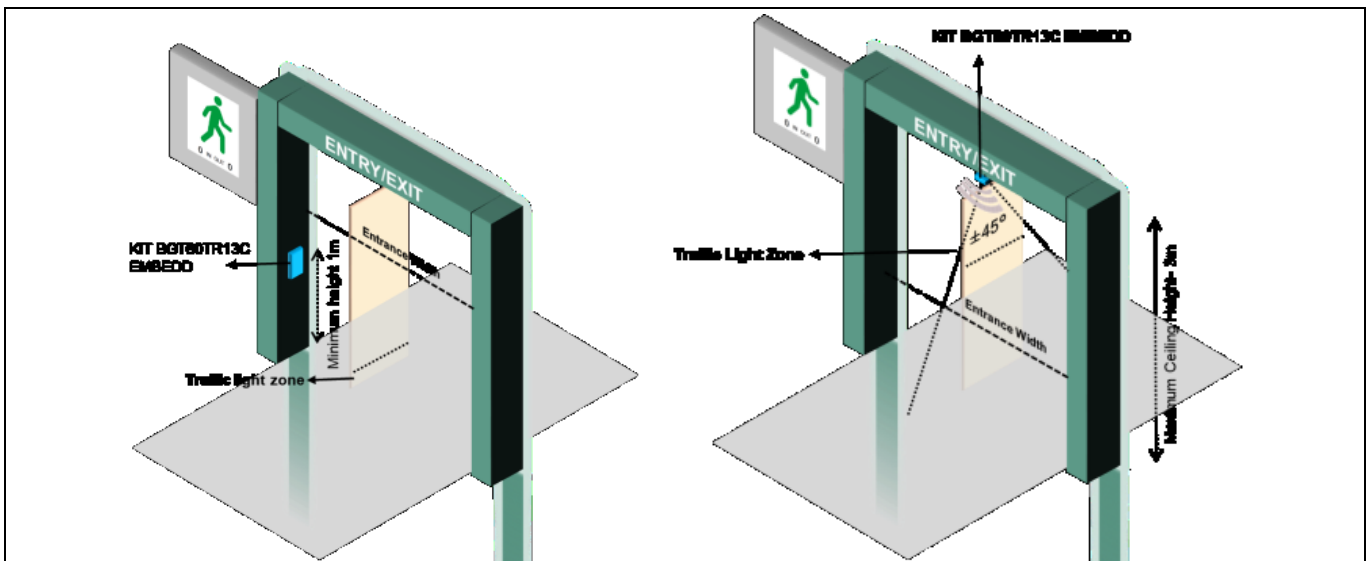

Figure 32 Radar mounted on the side of the door (left) and at the top of the door with the longer edge perpendicular to the passage (right)

Table of contents

6.5 Known limitations and recommendations

- The entrance counter solution is verified using CSK HW as a reference platform. It is provided as part of the CSK offered primarily for evaluation purposes on an “as is” basis (no liability/warranty). The user is responsible for evaluating, adapting and qualifying it as part of their products for their intended applications.
- The CSK HW (rapid IoT baseboard, sensor wing boards) is provided as a reference platform (functionally verified but not qualified) enabling functional tests only for development purposes. It is not aimed at supporting qualification tests and reliability assessments.
- A miscount might occur when the user stands still in the FoV, e.g. directly under the sensor, for more than 2 to 3 s.
- The current solution is only verified for people walking in and out of the entrance area. It has not been tested with non-human moving objects (e.g., pets, service robots, etc.).
- The current solution supports counting of people entering or exiting entrance one after another (one at a time).
- Elimination of target detection through the wall is not supported.
- The solution is not designed/optimized for detection through glass walls.

6.6 Recommendations

- It is recommended to use the solution as top/ceiling mount for optimal functional performance.
- For top/ceiling mount, it is recommended to limit the maximum range of the solution to the height of the sensor board from the ground for good performance.
- The solution might react to certain moving conditions (e.g., moving curtains, plant movements, facing a wall within its active zone, etc.) so, for the time being, the user is recommended to either install it in a location where such conditions can be avoided, or adapt the maximum range accordingly.
- For optimal results, the user is recommended not to install the reference HW board in corners where the radar chip is facing a side wall, to avoid multiple reflections.

Table of contents

7 Hardware description

This chapter introduces you to various features of the XENSIV™ KIT BGT60TR13C. Firstly, CYSBSYSKIT-DEV-01 and its components are described. Secondly, XENSIV™ BGT60TR13C wing and its components are described.

7.1 CYSBSYSKIT-DEV-01

7.1.1 Baseboard components

The Rapid IoT connect developer kit is designed for evaluation of the CYSBSYS-RP01 Rapid IoT connect module on a form factor that is compatible with Breadboard and Feather wings. The CYSBSYS-RP01 SoM is a turnkey module that enables secure, scalable, and reliable compute and connect. It has all hardware resources of PSoC™ 6 MCU including Cortex®-M0+ and Cortex®-M4 cores available for the user. Please note that Cortex® M0+ will be used as network processor if you intend to use Infineon® Rapid IoT cloud platform and Subsystem Communication Layer for IoT Services.

The Rapid IoT connect developer kit contains CYSBSYS-RP01 Rapid IoT connect module with 512-Mbit SPI NOR Flash, Optiga Trust M Secure controller, NTC thermistor, reset button, user button, user LED, on-board programmer/debugger (KitProg3) along with USB-UART interface and USB-I2C interface in a compact form factor with stackable headers containing 1 SPI Interface, 1 UART interface, 1 I2C interface and 14 GPIOs where 6 pins can be configured as ADC as well. Apart from these, it also contains various power circuitry such as single cell Li-Po battery charger, buck-boost converter, LDOs, load switches, etc.

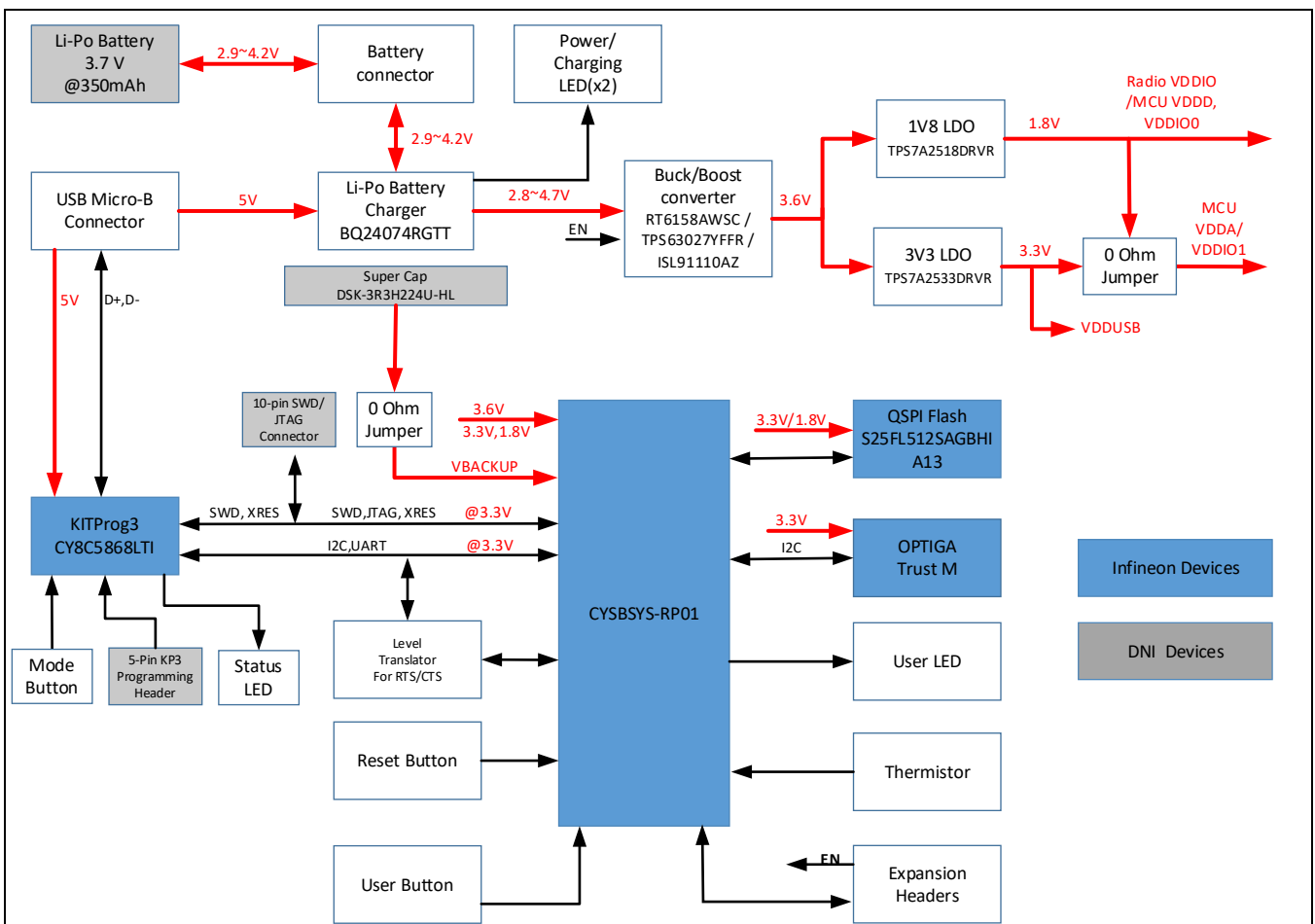

Figure 33 Hardware block diagram

Table of contents

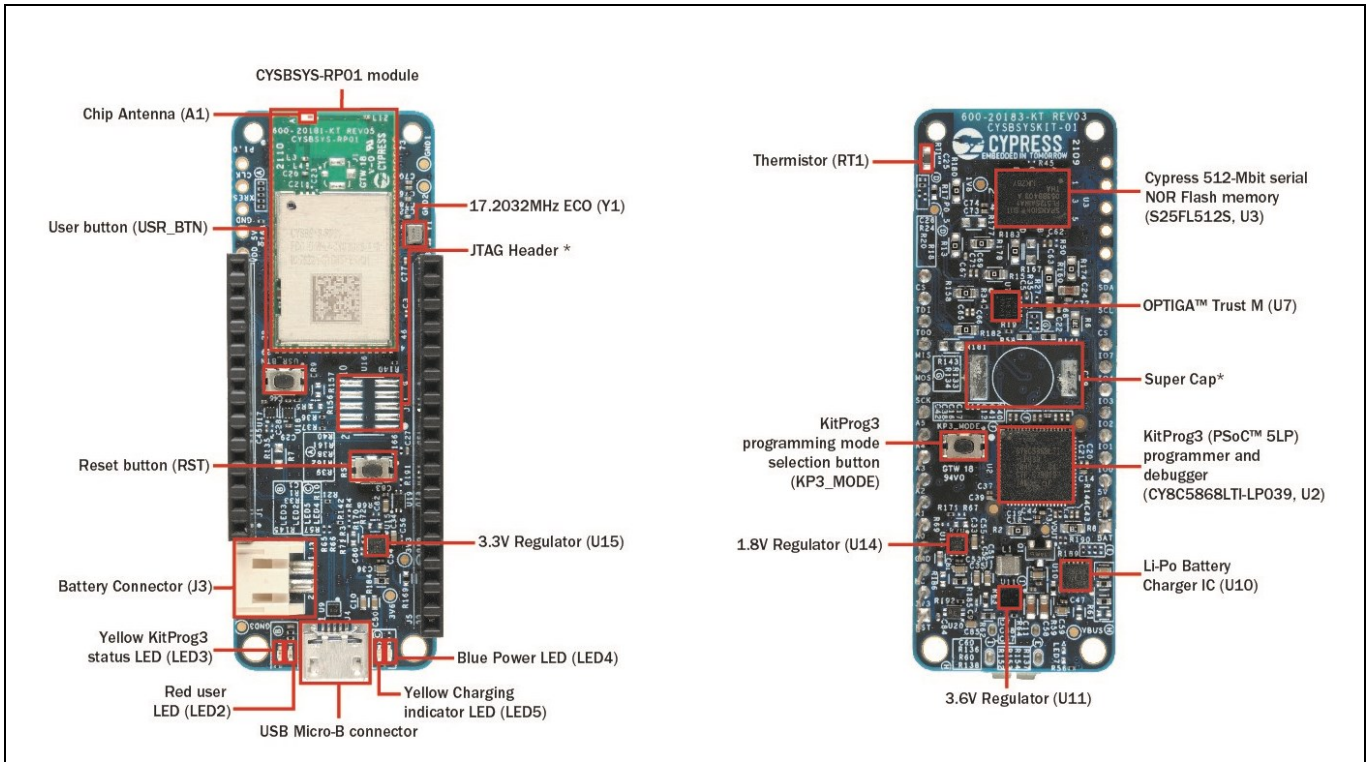

Figure 34 Rapid IoT connect developer kit top and bottom views

1. **CYSBSYS-RP01 module:** Rapid IoT connect module containing PSoC™ 6 MCU and Wi-Fi Bluetooth® radio with a chip antenna.
2. **17.2032Mhz ECO:** External Crystal Oscillator (ECO) for PSoC™ 6 MCU.
3. **JTAG header:** A 10-pin external programming header is provided to use external programmers like MiniProg4 to program the PSoC™ 6 MCU device over the SWD interface. This header is not loaded by default.
4. **Expansion headers (J1, J5):** These headers provide connectivity to PSoC™ 6 MCU GPIOs, and are compatible with Adafruit Feather pin mapping.
5. **User button:** Used for the user application. The PSoC™ 6 MCU pin is connected to power; when the push button is pressed, the PSoC™ 6 MCU pin is grounded.
6. **Chip antenna (A1):** An ultra-miniature chip antenna that supports 5GHz and 2.4GHz bands.
7. **3.3V regulator:** Regulator used to power the analog domain of PSoC™ 6 MCU.
8. **Power LED (LED4):** Blue LED that indicates the status of power supplied to the board.
9. **Charging LED (LED5):** Yellow LED that indicates the LiPo battery charging status by glowing continuously. If the LiPo battery is not connected, this LED does not glow. If the board is powered solely from the LiPo battery, this LED does not glow.
10. **USB connector:** The USB cable connects between this USB connector and the PC, used to power the entire board as well as the connection to the on-board KitProg3 programmer/debugger.
11. **User LED (LED2):** Active LOW red LED, so the PSoC™ 6 MCU pin must be driven to ground to turn ON the LED.
12. **KitProg3 status LED (LED3):** Yellow LED (LED3) that indicates the status of KitProg3. For details on the KitProg3 status, see the "Programming and Debugging" sub-section in the "KitProg3: On-board programmer/debugger" section of this document.
13. **Battery connector (J3):** Used for connecting a 3.7-V LiPo battery.

Table of contents

- 14. **Infineon® 512Mbit serial NOR flash memory (S25FL512S, U6):** The 512-Mbit S25FL512SAGBHIA13 NOR flash is connected to the serial memory interface (SMIF) of the PSoC™ 6 MCU device. The NOR device can be used for both data and code memory with execute-in-place (XIP) support and encryption.
- 15. **Optiga Trust M (U7):** Optiga Trust M is an advanced security controller with built-in tamper-proof NVM for secure storage and symmetric/asymmetric crypto engine to support ECC 256, AES-128 and SHA-256. This technology greatly enhances the overall system security.
- 16. **Super cap:** Used to power the backup domain of PSoC™ 6 MCU. This is no load by default.
- 17. **KitProg3 (PSoC™ 5LP) programmer and debugger (CY8C5868LTI-LP039, U2):** The PSoC™ 5LP device (CY8C5868LTI-LP039) serving as KitProg3 is a multi-functional system which includes a SWD programmer, debugger, USB-I2C bridge, and USB-UART bridge. For more details, see the [KitProg3 user guide](#).
- 18. **LiPo battery charger IC:** Used for charging the LiPo battery.
- 19. **3.6V regulator:** Powers the radio.
- 20. **1.8V regulator:** Powers the PSoC™ 6 MCU digital domain.
- 21. **KitProg3 programming mode selection button:** Used to switch between various modes of operation of KitProg3 (CMSIS-DAP/Bulk, CMSIS-DAP/HID mode and DAPLink mode). For more details, see the [KitProg3 user guide](#).
- 22. **CYSBSYS-RP01 reset button:** Used to reset the PSoC™ 6 MCU device. This button connects the PSoC™ 6 MCU reset (XRES) pin to ground.
- 23. **Thermistor (RT1):** On-board NTC thermistor for ambient temperature sensing.

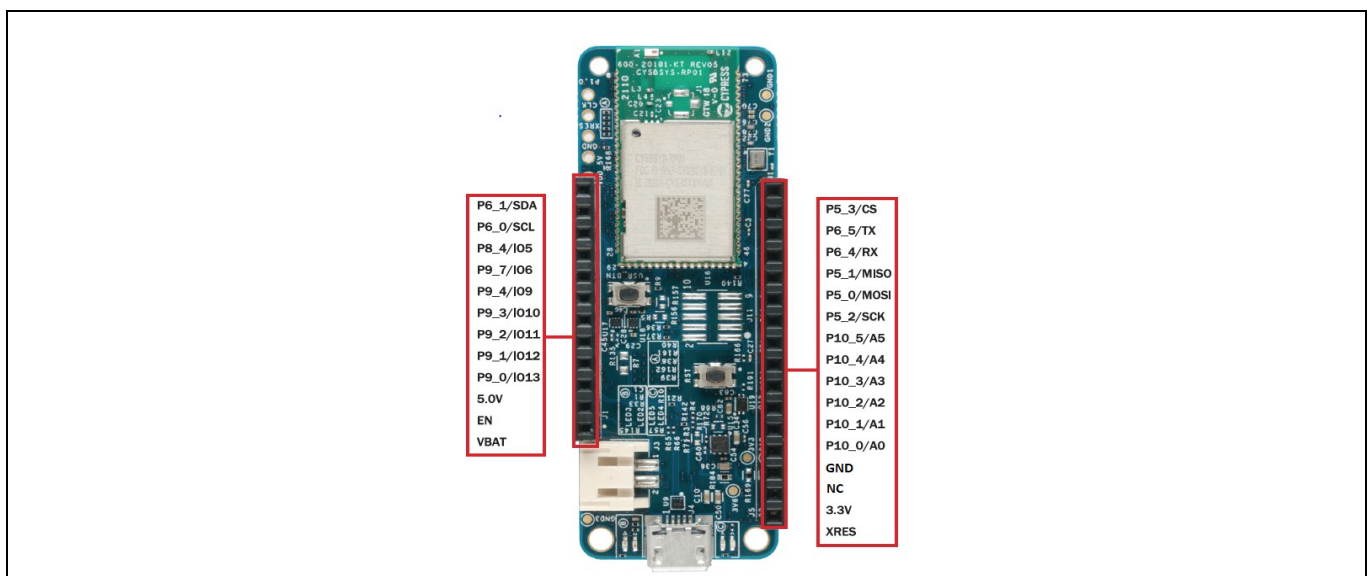

Figure 35 CYSBSYSKIT-DEV-01 pinouts

Table 4 CYSBSYSKIT-DEV-01 pinout

Header mapping	Primary on-board function	PSoC™ 6 MCU pin	Feather wing compatibility	Connection details
J1.1	VBAT	–	–	LiPo battery voltage
J1.2	EN	–	–	Input used to turn off on-board regulators
J1.3	VBUS	–	–	USB power
J1.4	GPIO	P9_0	GPIO13	–

Table of contents

Header mapping	Primary on-board function	PSoC™ 6 MCU pin	Feather wing compatibility	Connection details
J1.5	GPIO	P9_1	GPIO12	–
J1.6	GPIO	P9_2	GPIO11	–
J1.7	GPIO	P9_3	GPIO10	–
J1.8	GPIO	P9_4	GPIO9	–
J1.9	GPIO	P9_7	GPIO6	–
J1.10	GPIO	P8_4	GPIO5	–
J1.11	I2C SCL	P6_0	SCL	Connected to KitProg3. Note that this pin has a 4.7K pull-up for I2C communication.
J1.12	I2C SDA	P6_1	SDA	Connected to KitProg3. Note that this pin has a 4.7K pull-up for I2C communication.
J5.1	XRES	XRES	XRES	–
J5.2	3.3V	VDDA, VDDIO	VCC	Analog voltage for PSoC™ 6 MCU
J5.3	NC	–		Not connected
J5.4	GND	–	GND	–
J5.5	Analog GPIO	P10_0	A0	–
J5.6	Analog GPIO	P10_1	A1	–
J5.7	Analog GPIO	P10_2	A2	–
J5.8	Analog GPIO	P10_3	A3	–
J5.9	Analog GPIO	P10_4	A4	–
J5.10	Analog GPIO	P10_5	A5	–
J5.11	SPI Clock	P5_2	SCK	SPI clock
J5.12	SPI MOSI	P5_0	MOSI	SPI master out / slave in (MOSI)
J5.13	SPI MISO	P5_1	MISO	SPI master in / slave out (MISO)
J5.14	UART RX	P6_4	RX	Connected to KitProg3
J5.15	UART TX	P6_5	TX	Connected to KitProg3
J5.16	SPI CS	P5_3	GPIO14	SPI chip select

Table 5 On-board peripheral connections

PSoC™ 6 MCU pin#	Board function
P0_4	User button
P5_4	KitProg3 UART - RX
P5_5	KitProg3 UART - TX
P5_6	KitProg3 UART - RTS
P5_7	KitProg3 UART - CTS
P6_0	KitProg3 I2C SCL
P6_1	KitProg3 I2C SDA
P6_6	KitProg3 SWD data
P6_7	KitProg3 SWD CLK

Table of contents

PSoC™ 6 MCU pin#	Board function
P10_6	Thermistor power
P10_7	Thermistor ADC IN
P11_1	User LED
P11_2	QSPI chip select
P11_3	QSPI DAT3
P11_4	QSPI DAT2
P11_5	QSPI DAT1
P11_6	QSPI DAT0
P11_7	QSPI CLK
P12_6	ECO_In
P12_7	ECO_Out
XRES_L	Reset button

7.1.2 Hardware functional description

7.1.3 CYSBSYS-RP01 module

The Rapid IoT connect SoM is the easiest way to provide a secure, scalable, and reliable connection from your device to your cloud. The Rapid IoT connect SoM is a pre-certified 802.11ac-friendly dual-band (2.4 and 5.0 GHz) Wi-Fi and Bluetooth® 5.0-compliant combo radio with an integrated PSoC™ 6 Secure IoT MCU provided in an easy-to-use package. Included within the SoM are the crystals, oscillators, RF switches, passive components, and antenna to help accelerate development of your secure IoT products. It provides up to 51 I/Os in a 26.6 x 14.0 x 2.5-mm castellated surface mount PCB for easy manufacturing. See the datasheet at this [location](#) for additional details.

7.1.4 PSoC™ 5LP

An on-board PSoC™ 5LP device (CY8C5868LTI-LP039) is used as KitProg3 to program and debug the PSoC™ 6 MCU device. The PSoC™ 5LP device connects to the USB port of the PC through a USB connector and to the SWD and other communication interfaces of PSoC™ 6 MCU. The PSoC™ 5LP device is a system-level solution providing MCU, memory, analog, and digital peripheral functions in a single chip. For more information, see the [PSoC™ 5LP web page](#) and the [CY8C58LPxx family datasheet](#).

Table of contents

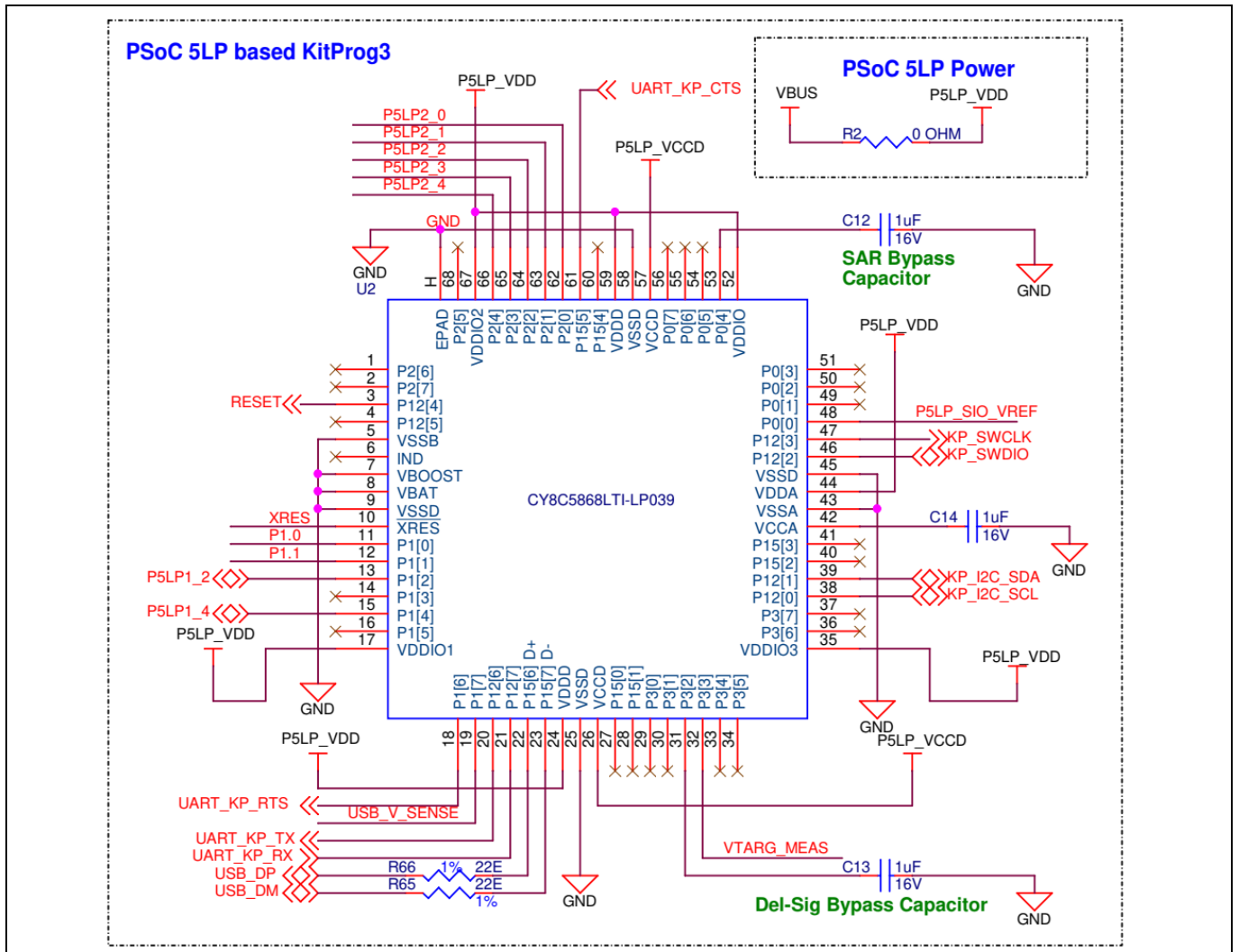

Figure 36 KitProg3 programmer

Table of contents

7.1.5 Serial interconnection between PSoC™ 5LP and module

In addition to its use as an on-board programmer, the PSoC™ 5LP device functions as an interface for the USB-UART and USB-I2C bridges. The serial pins of the PSoC™ 5LP device are hard-wired to the I2C/UART pins of the PSoC™ 6 MCU device.

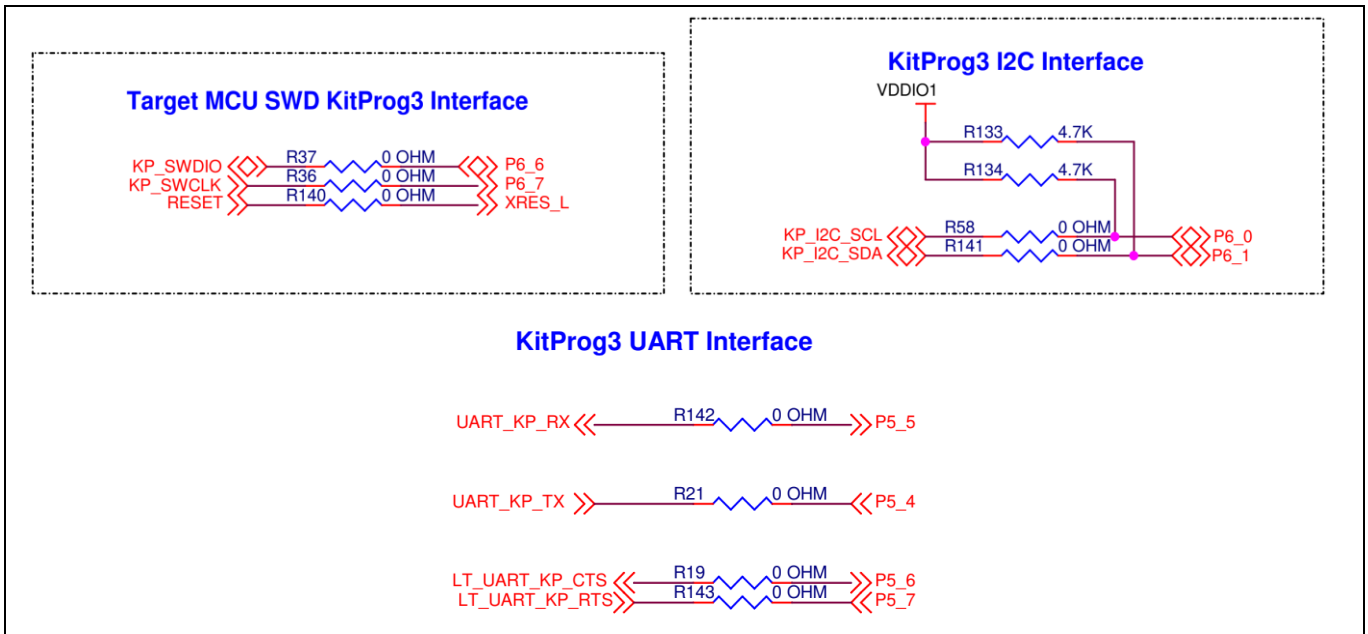

Figure 37 KitProg3 interface

7.1.6 Power supply system

The kit has the following input voltage sources:

- 5 V from KitProg3 USB Micro-B port (J4)
- LiPo battery @ 3.7 V, 350 mAh (J3)

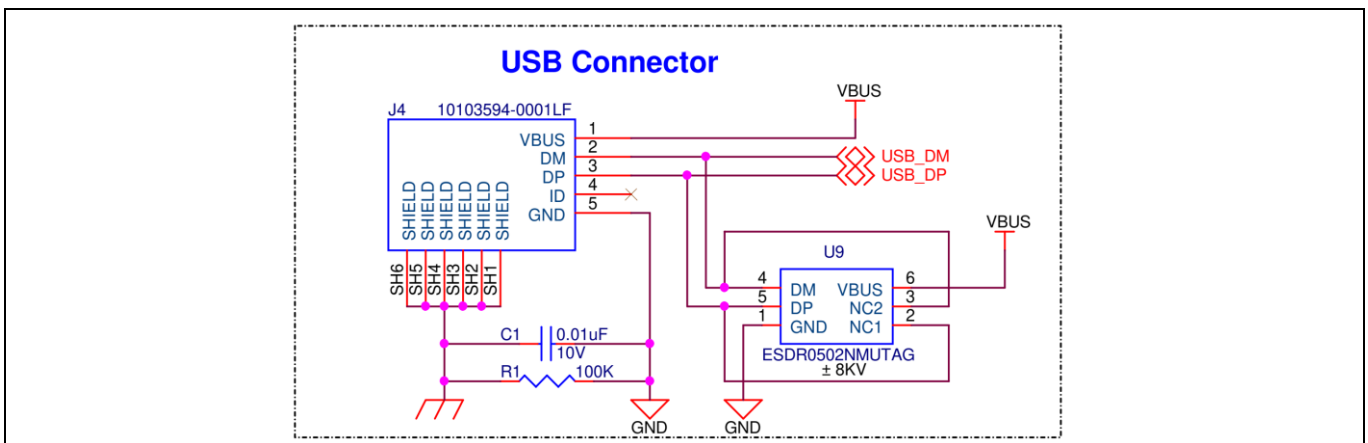

Figure 38 USB connector

The LiPo battery is connected to the LiPo battery charger IC (U10) with a 10µF bypass capacitor. The LiPo battery charger takes the VBUS (5V) from the USB connector (J4) as a source for charging the battery as well as the supply (VOUT) for other components when battery power is not available. A yellow LED (LED5) attached to the \overline{CHG} pin of the charger IC indicates the battery charging status by glowing continuously. It automatically turns off when

Table of contents

the battery is fully charged. The TS pin is meant for an external negative temperature coefficient (NTC) thermistor. In this kit, it is connected to GND through a 10K resistor. \overline{CE} is the charge enable pin which is kept low always to enable the charger circuit. EN2 and EN1 pins are used to set the maximum input current at input pin. EN2 is set as logic 1 through the 10K pull-up resistor (R154) and EN1 is set to logic 0 through the 10K pull-down resistor (R152), which sets the maximum input current to be adjusted by external resistor (R59) connected to pin ILIM. Currently, ILIM is designed to let 850 mA of current (R59). The output VOUT is decoupled with a 10 μ F and a 0.1 μ F capacitor. VOUT will be in the range VBUS to VBUS-0.237 V while powering from VBUS, and VBAT to VBAT-0.0625V while powering from the battery.

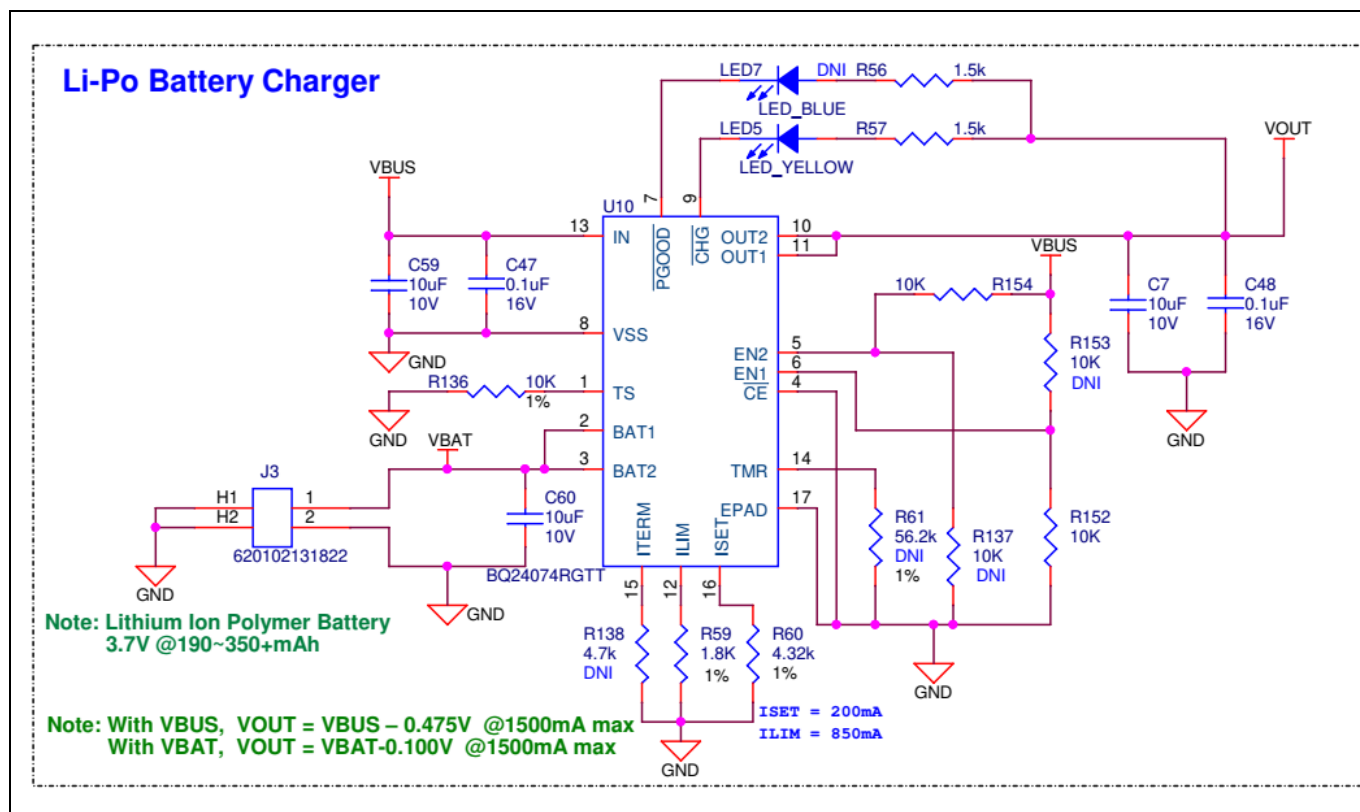

Figure 39 Battery charger

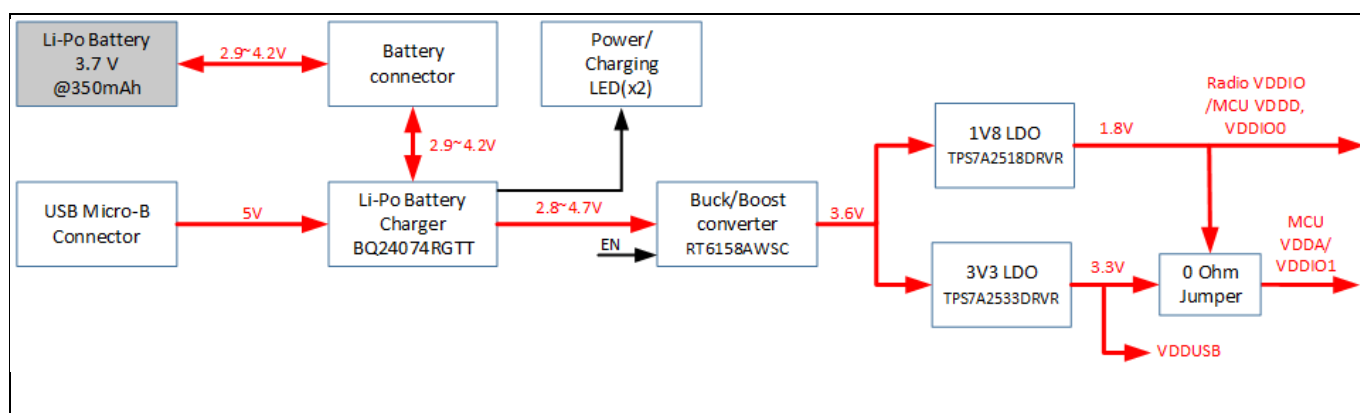

Figure 40 CYSBSYSKIT-DEV-01 power tree

The EN pin is an input used to turn off the on-board regulators. An on-board resistive pull-up ensures that regulators are on by default and an external trigger from wing board can be used to turn off the on-board supply.

Table of contents

7.1.7 Expansion headers

The Rapid IoT connect developer kit contains two single inline headers (J1 and J5). All pins of the PSoC™ 6 MCU device that are not dedicated to a function are connected to the stackable expansion headers. The I/O header signals include signals from PSoC™ 6 MCU and system power signals.

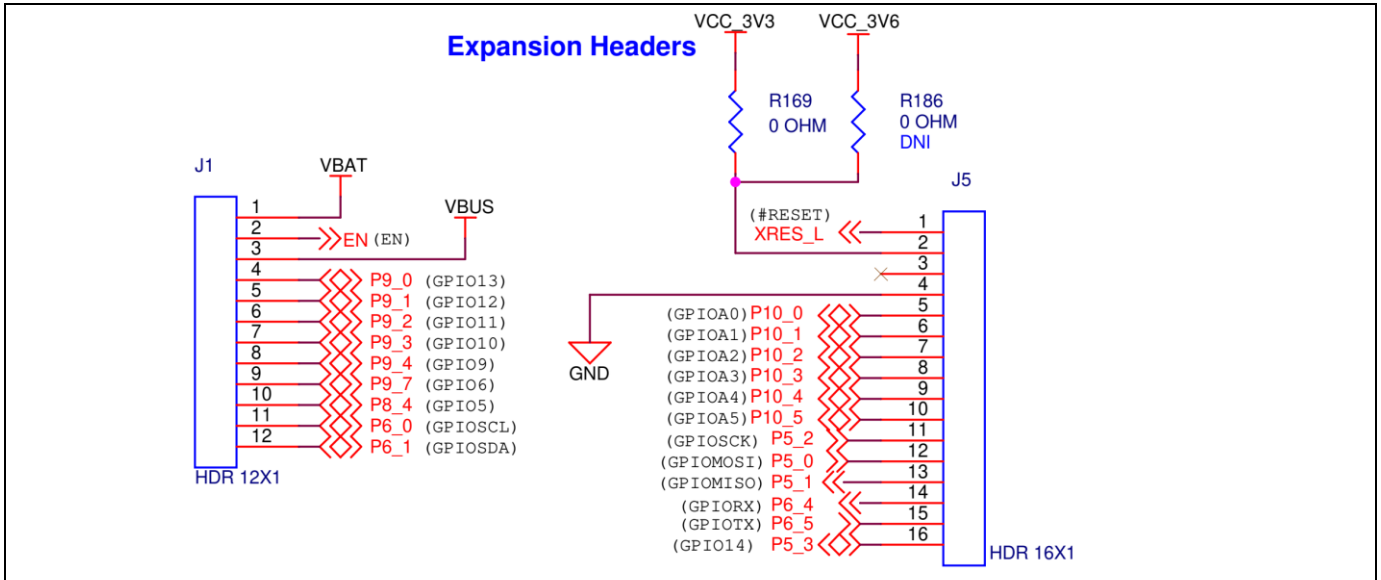

Figure 41 CYBSYSKIT-DEV-01 headers

7.1.8 QSPI

This board has a 24-BGA 512 Mbit QSPI NOR flash. This device uses a Serial Peripheral Interface (SPI) to communicate with the PSoC™ 6 MCU device. The device supports four-bit (Quad I/O) serial commands. The PSoC™ 6 MCU device supports up to 70MHz clock on the QSPI interface. 33Ω series termination resistors are provided as close as possible to the module footprint on the clock and all I/O lines.

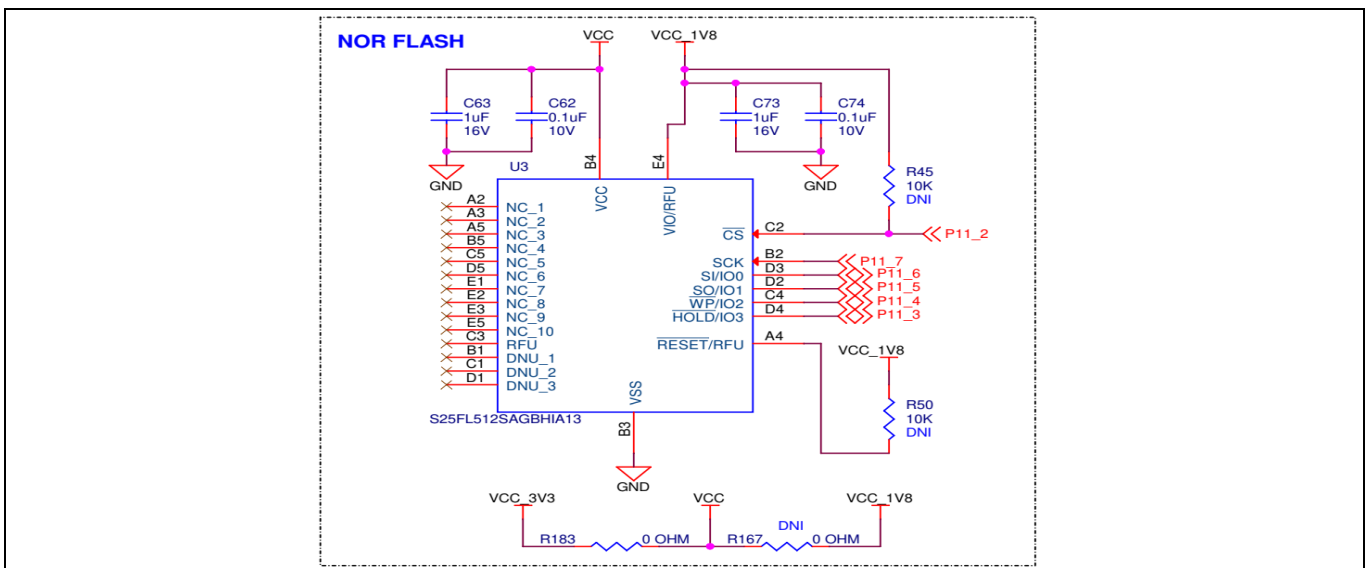

Figure 42 NOR Flash interface

Table of contents

7.1.9 LED

Rapid IoT connect developer kit has 1x RED user LED for general-purpose applications. The series resistor is 330Ω for limiting the current. The User LED is configured in active low mode and connected to pin P11_1 of the PSoC™ 6 MCU device.

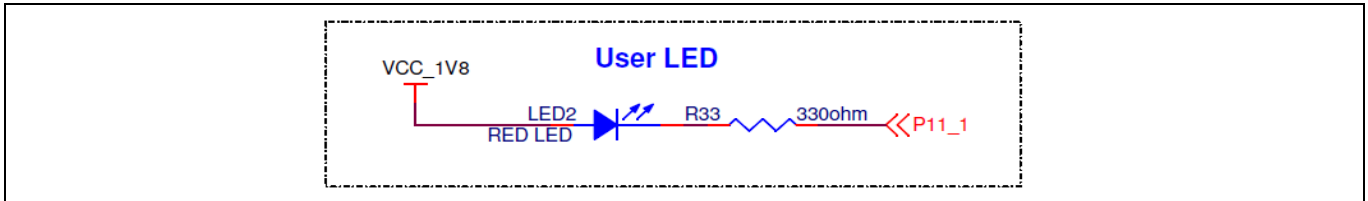

Figure 43 User LED

7.1.10 User button

The User button is used for general-purpose applications, and is connected to pin P0_4 of the PSoC™ 6 MCU device. It is configured in active low configuration by default. It is tied to the VBACKUP power rail through a 10K pull-up resistor (R9).

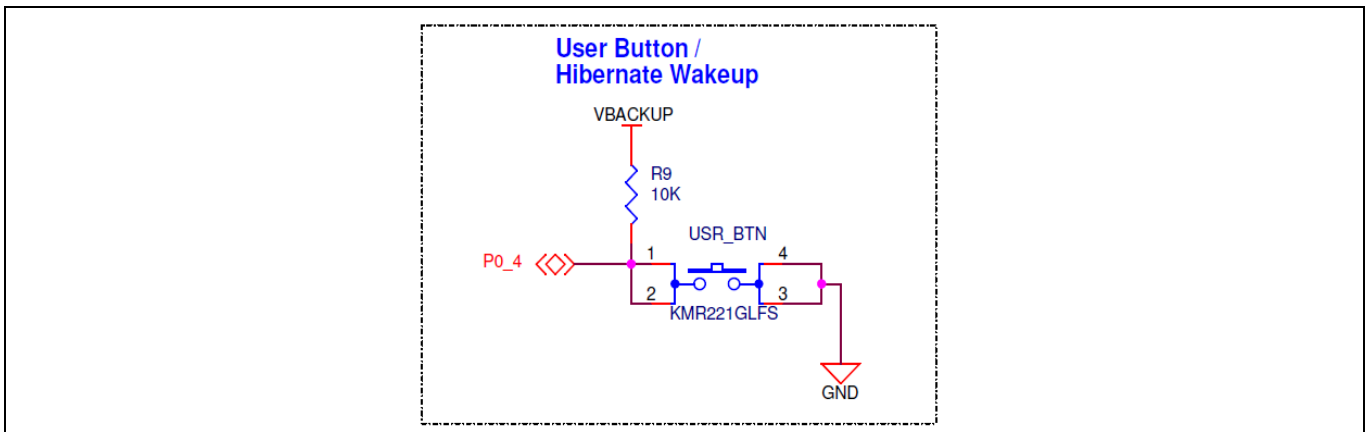

Figure 44 User button

7.1.11 ECO

The board has one crystal connected to the PSoC™ 6 MCU device: 17.2032-MHz ECO for audio applications. ECO pins ECO_IN and ECO_OUT are connected to the P12_6 and P12_7 pins of PSoC™ 6 MCU respectively.

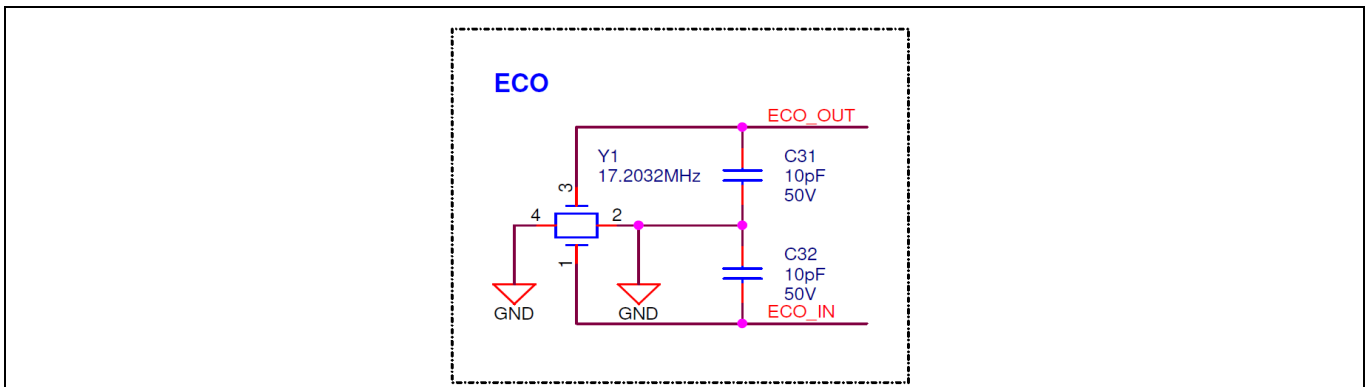

Figure 45 ECO crystal

Table of contents

7.1.12 10-pin SWD/JTAG programming header

A 10-pin (50-mil pitch) SWD header (J11) is provided to program and debug the target PSoC™ 6 MCU device using an external programmer like MiniProg4. This header is not populated by default.

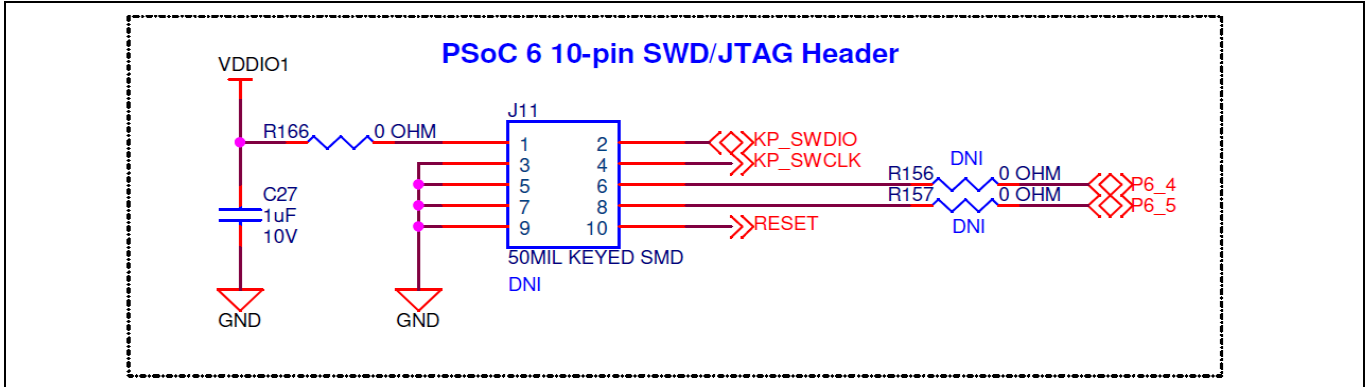

Figure 46 Programmer header

7.1.13 KitProg3: on-board programmer/debugger

The Rapid IoT connect developer kit can be programmed and debugged using the on-board KitProg3. KitProg3 is an on-board programmer/debugger with USB-UART and USB-I2C functionality. The Infineon® PSoC™ 5LP device is used to implement KitProg3 functionality. For more details on the KitProg3 functionality, see the [KitProg3 user guide](#).

7.1.14 Programming and debugging

- Connect the board to the PC using the Micro USB cable.
- It enumerates as a USB composite device if you are connecting it to your PC for the first time. KitProg3 can operate either in CMSIS-DAP bulk mode (default), or DAPLink mode. KitProg3 also supports CMSIS-DAP bulk with two UARTs. Programming is faster with the bulk mode. The status LED (Yellow) is always ON in bulk mode, and ramping at 2Hz rate in DAPLink mode.
- Press and release the mode select button to switch between these modes.
- If you do not see the desired LED status, see the [KitProg3 user guide](#) for details on the KitProg3 status and troubleshooting instructions.

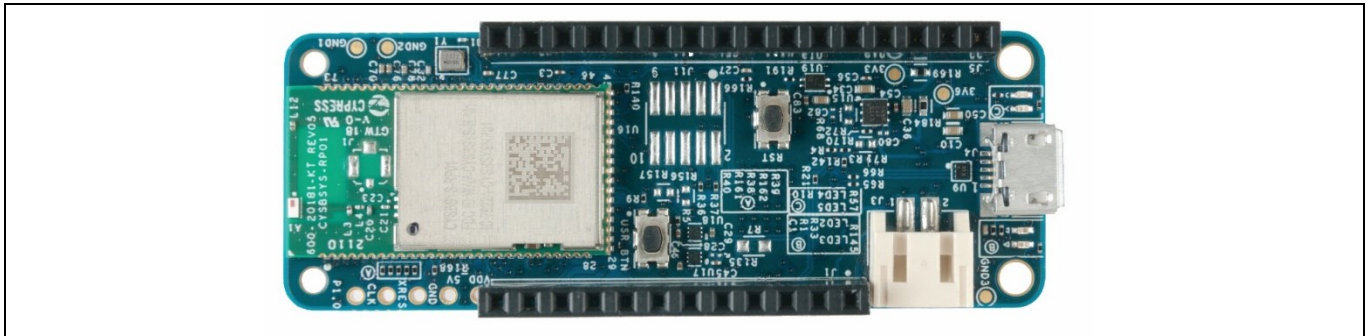

Figure 47 CY5BSYSKIT-DEV-01 top view

Table of contents

7.1.15 USB-UART bridge

The KitProg3 device on the Rapid IoT connect developer kit can act as a USB-UART bridge. The primary UART and flow control lines between the PSoC™ 6 MCU device and KitProg3 are hardwired on the board as shown in the figure below. This UART is shared between the NP and CP; the messages from both the processors appear on this same port.

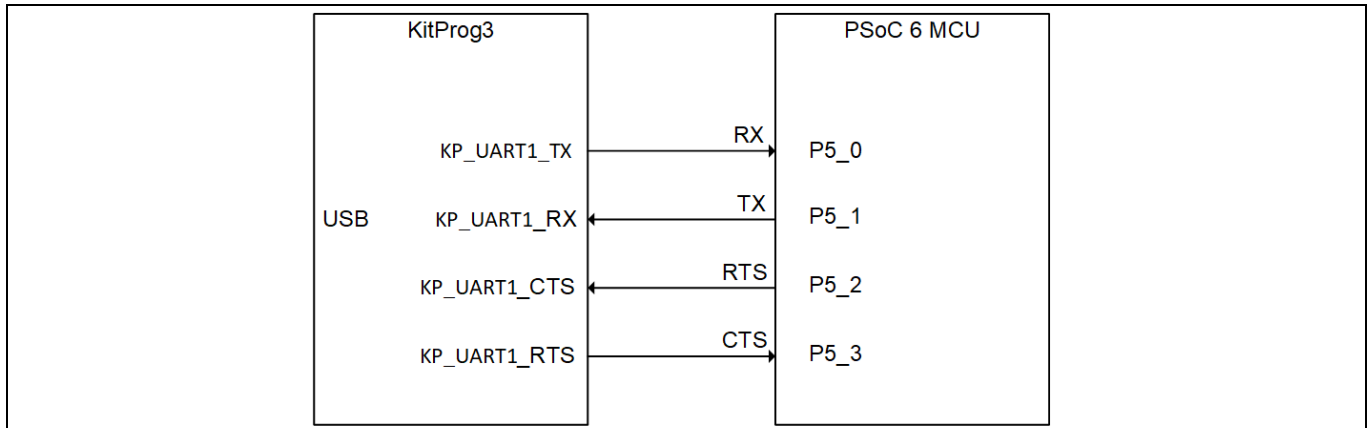

Figure 48 UART connection between KitProg3 and PSoC™ 6 MCU

7.1.16 USB-I2C bridge

The KitProg3 device can function as a USB-I2C bridge and can communicate with the Bridge Control Panel (BCP) software which acts as an I2C master. BCP is installed as part of the PSoC™ Programmer tool (download from this [location](#)). The I2C lines on the PSoC™ 6 MCU device are hard-wired on the board to the I2C lines of KitProg3, with on-board pull-up resistors as shown in the figure. The USB-I2C bridge supports I2C speeds of 50kHz, 100kHz, 400kHz, and 1MHz. For more details on the KitProg3 USB-I2C functionality, see the [KitProg3 user guide](#).

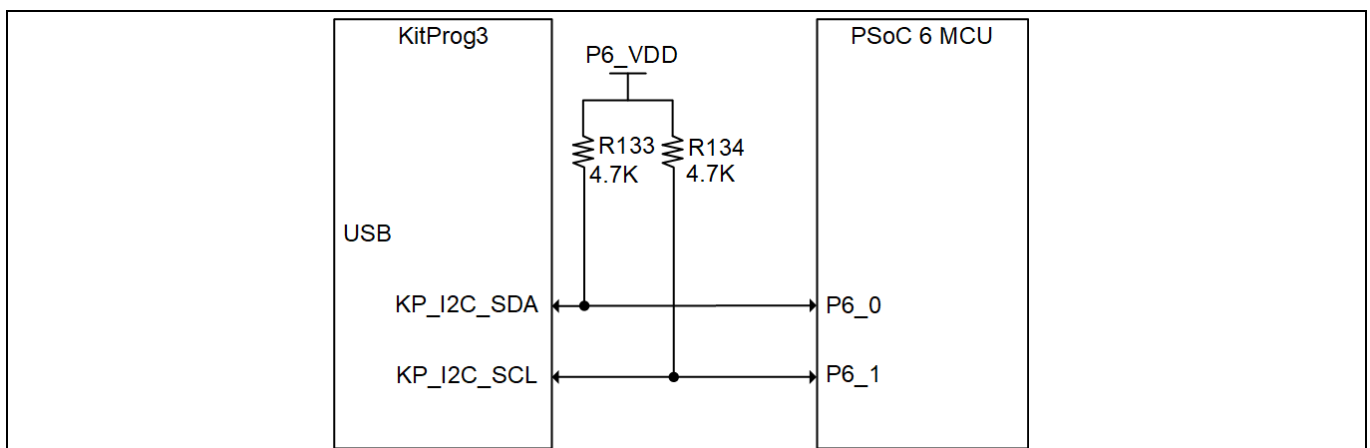

Figure 49 I2C connection between KitProg3 and PSoC™ 6 MCU

Table of contents

7.2 XENSIV™ BGT60TR13C wing

7.2.1 Wing board components

Figure 50, Figure 6 and Table 6 describe the components mounted on the XENSIV™ BGT60TR13C radar wing.

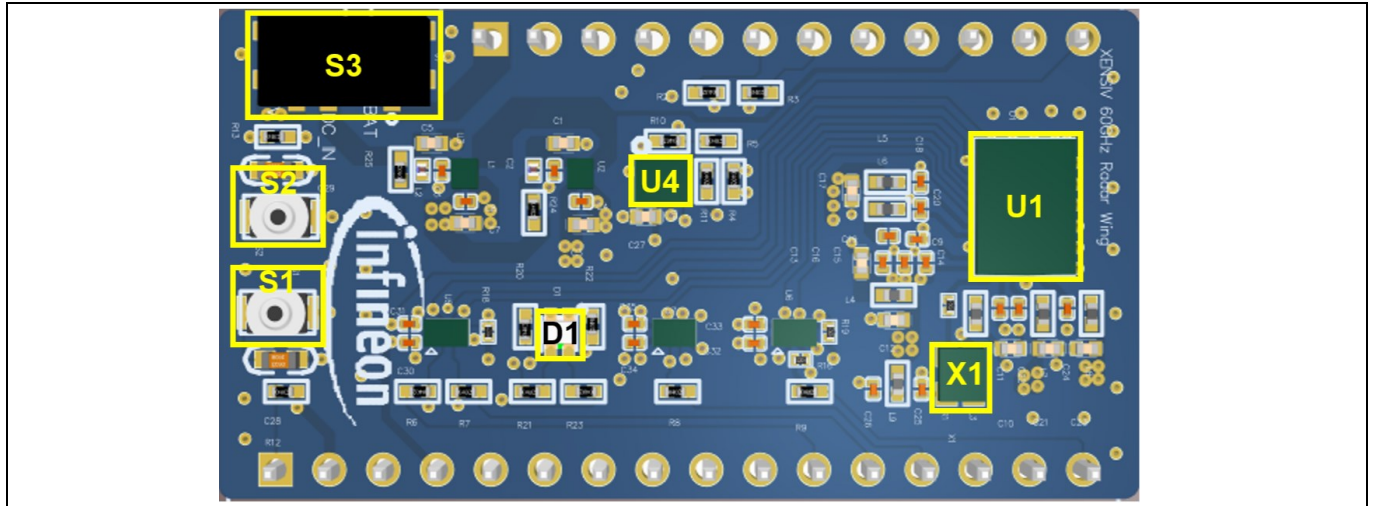

Figure 50 Front view of the XENSIV™ BGT60TR13C radar wing

Table 6 Onboard HW description

Designator	Function
U1	XENSIV™ BGT60TR13C
X1	80 MHz CMOS oscillator
U4	XENSIV™ DPS368 (digital barometric pressure sensor)
D1	Tri-colored LED
S1	System reset button, active low
S2	User button, active low
S3	To select the board power supply from CYCBSYSKIT-DEV-01 rapid IoT baseboard: USB5V or from lithium battery supply of the kit
J1 J2	Adafruit headers

7.3 Adafruit feather-compatible connectors

Figure 51 highlights the 28-pin Adafruit feather-compatible adaptor headers. The function of the respective header pins is described in Table 3. The image also shows the test points which were used for testing the boards in the lab or production.

Table of contents

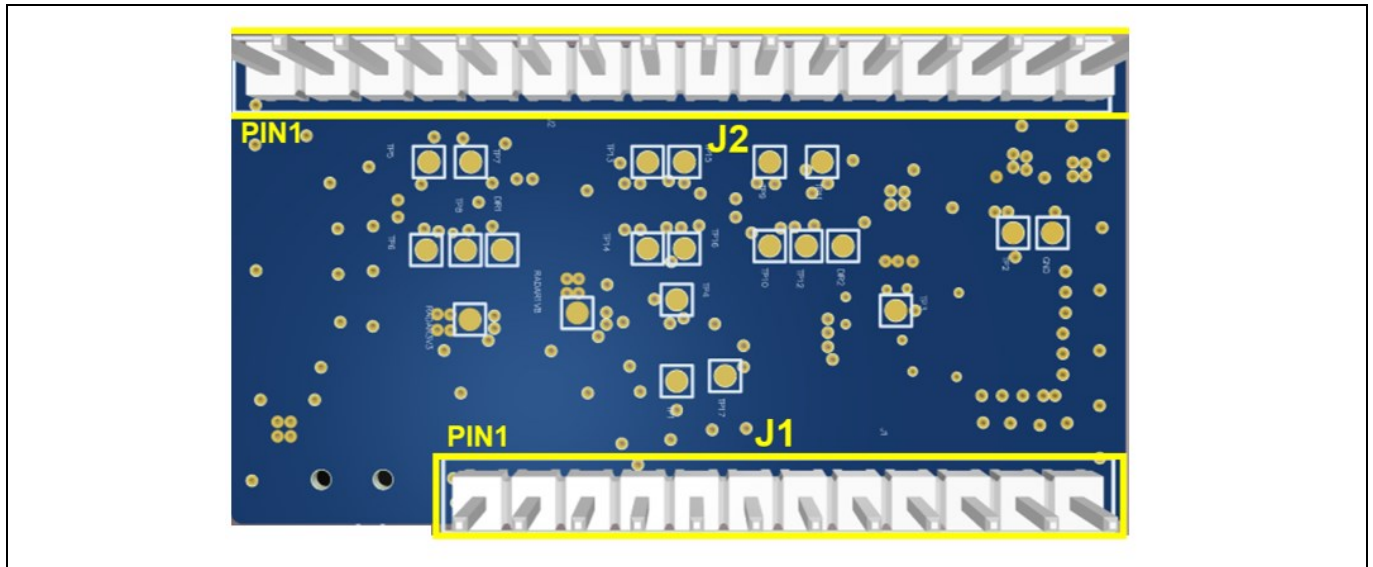

Figure 51 Adafruit headers and test points on the back view of the XENSIV™ BGT60TR13C radar wing

Table 7 Adafruit feather-compatible pin-out

Header mapping	Primary onboard function	PSoC 6 MCU pin (rapid IoT baseboard)	Adafruit feather-compatible mapping (rapid IoT baseboard)	Adafruit feather-compatible mapping (radar wing board)	Details
J1.1	V _{BAT}	–	–	VBAT	LiPo battery voltage
J1.2	EN	–	–	–	Not connected
J1.3	V _{BUS}	–	–	5 V	USB power
J1.4	GPIO	P9_0	GPIO13	–	Not connected
J1.5	GPIO	P9_1	GPIO12	–	Not connected
J1.6	GPIO	P9_2	GPIO11	RST_Feather	RST
J1.7	GPIO	P9_3	GPIO10	IRQ_Feather	IRQ
J1.8	GPIO	P9_4	GPIO9	–	Not connected
J1.9	GPIO	P9_7	GPIO6	USR_BUT	User button
J1.10	GPIO	P8_4	GPIO5	en_LDO_Radar	Enable the LDOs (3.3 V and 1.8 V) on radar wing board for radar sensor
J1.11	I ² C SCL	P6_0	SCL	I2C_SCL_Feather	Connected to KitProg3. Note that this pin has a 4.7k pull-up for I ² C communication.
J1.12	I ² C SDA	P6_1	SDA	I2C_SDA_Feather	Connected to KitProg3. Note that this pin has a 4.7k pull-up for I ² C communication.

Table of contents

J2.1	XRES	XRES	XRES	nRESET	Reset button
J2.2	3.3 V	VDDA, VDDIO	VCC	3V3	Analog voltage for PSOC 6 MCU
J2.3	NC	–	NC	–	Not connected
J2.4	GND	–	GND	GND	Ground
J2.5	Analog GPIO	P10_0	A0	RGB_RED	RGB red color
J2.6	Analog GPIO	P10_1	A1	RGB_GREEN	RGB green color
J2.7	Analog GPIO	P10_2	A2	RGB_BLUE	RGB blue color
J2.8	Analog GPIO	P10_3	A3	–	Not connected
J2.9	Analog GPIO	P10_4	A4	–	Not connected
J2.10	Analog GPIO	P10_5	A5	–	Not connected
J2.11	SPI clock	P5_2	SCK	SPI_CLK_Feather	SPI clock
J2.12	SPI MOSI	P5_0	MOSI	SPI_MOSI_Feather	SPI master out/slave in (MOSI)
J2.13	SPI MISO	P5_1	MISO	SPI_MISO_Feather	SPI master in/slave out (MISO)
J2.14	UART RX	P6_4	RX	–	Not connected
J2.15	UART TX	P6_5	TX	–	Not connected
J2.16	SPI CS	P5_3	GPIO	SPI_CSN_Feather	SPI chip select

7.3.1 Power supply

The kit can be powered from a 3.7 V LiPo battery or via a USB cable from an external 5 V power supply. The battery is automatically charged when the system is connected to an external power supply.

Note: The radar wing board must be manually switched to either battery or external 5 V supply (switch S3 in Figure 50).

7.3.2 Mechanical buttons

Table 8 Abbreviations used in this document

Abbreviation	Description
S1	System reset
S2	User button – executed function can be individually programmed by user

Table of contents

Appendix A: Hardware design

The design of the shield was realized using the Altium PCB design tool. The Altium design files are available on request.

A1. Schematics

A1.1 Sensors

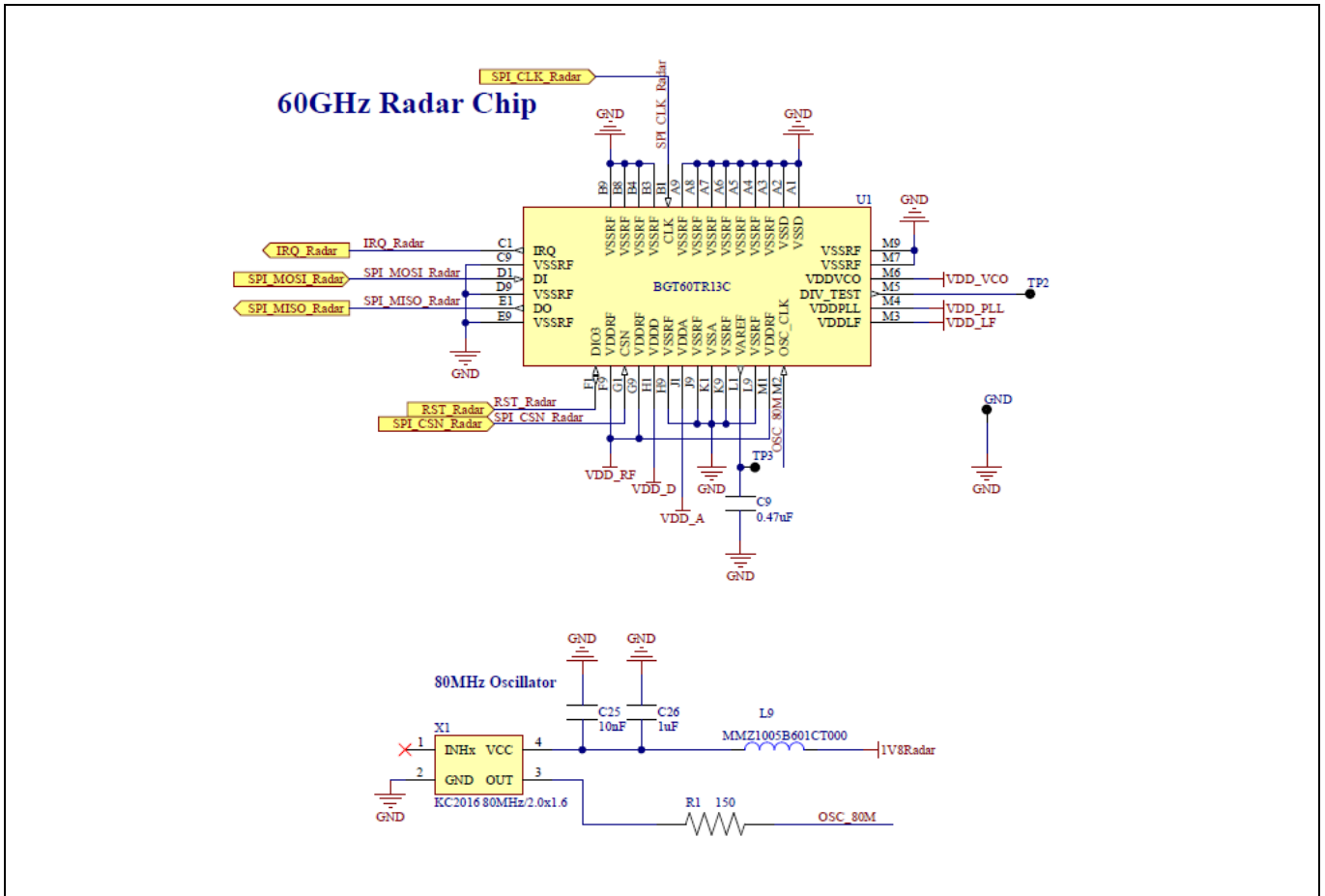

Figure 52 Schematic of XENSIV™ BGT60TR13C radar with 80 MHz oscillator

Table of contents

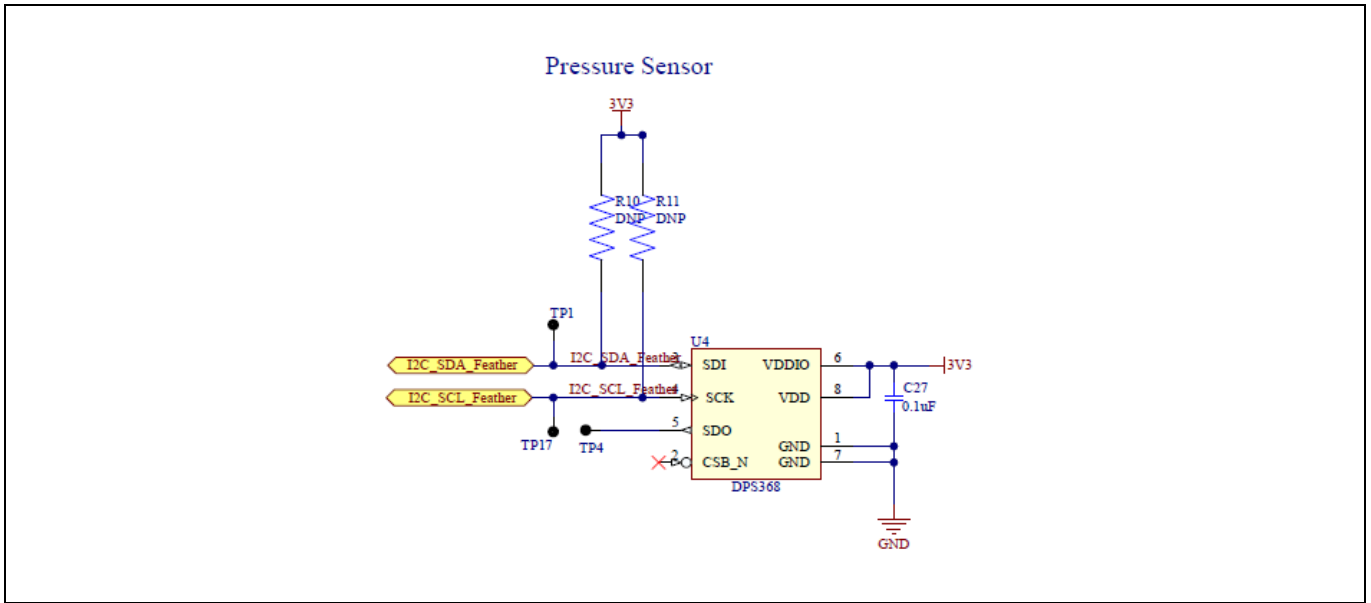

Figure 53 Schematic of XENSIV™ DPS368 pressure sensor

A1.2 Adafruit feather-compatible headers

Figure 4 shows the pin assignment of J1 and J2 on the XENSIV™ BGT60TR13C radar wing. The Adafruit feather-compatible header is used to plug into the CYCBSYSKIT-DEV-01 rapid IoT connect developer kit.

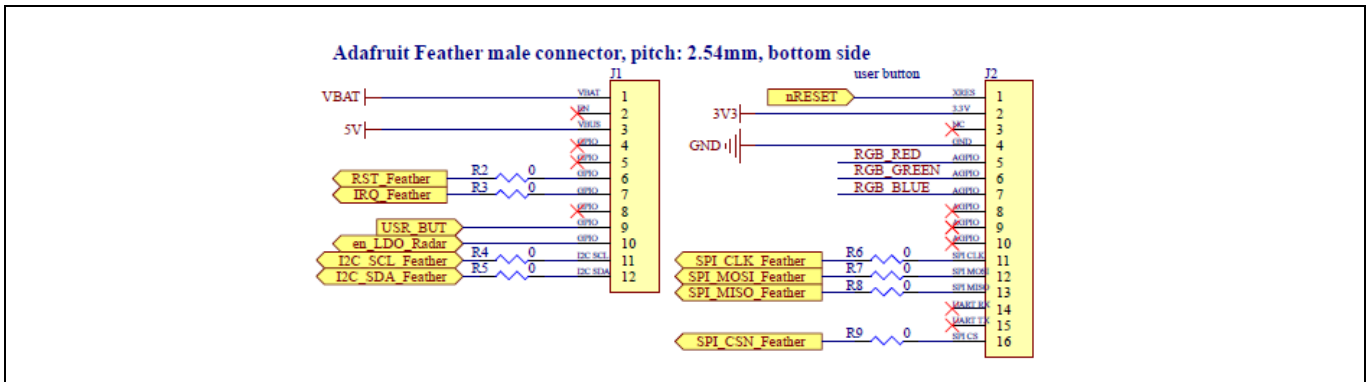

Figure 54 Schematic of Adafruit headers

A1.3 User interface (buttons, LEDs)

The user interface on the wing board consists of two mechanical buttons and three LEDs.

Table of contents

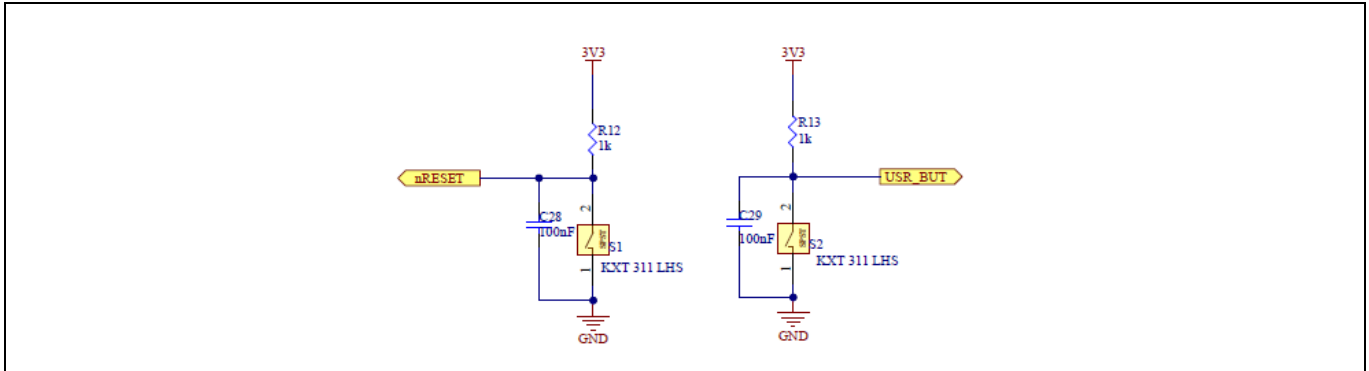

Figure 55 Schematic of reset (S1) and user button (S2)

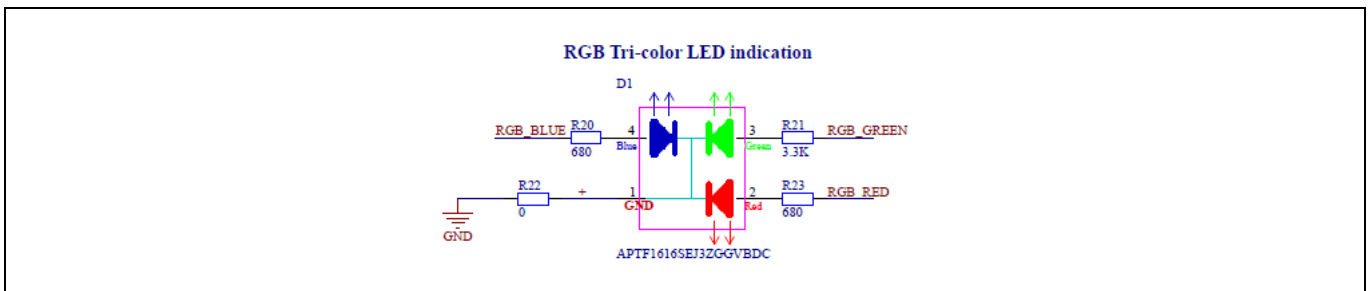

Figure 56 Schematic of LEDs

A1.4 Others

Figure 57 shows the board power selection.

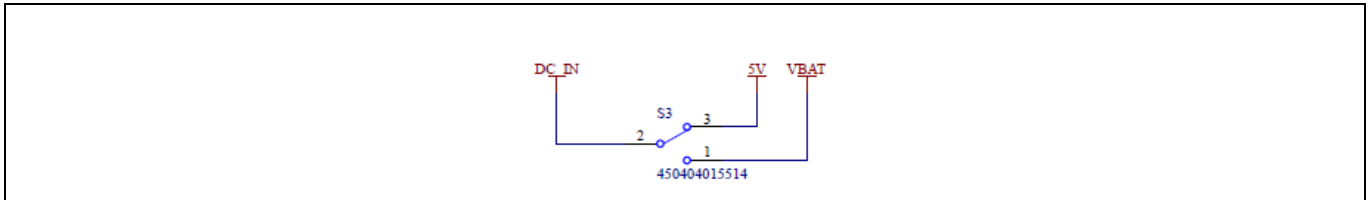

Figure 57 Board power selection (S3)

Figure 58 shows the voltage regulator circuit to provide stable power supply to the radar sensor.

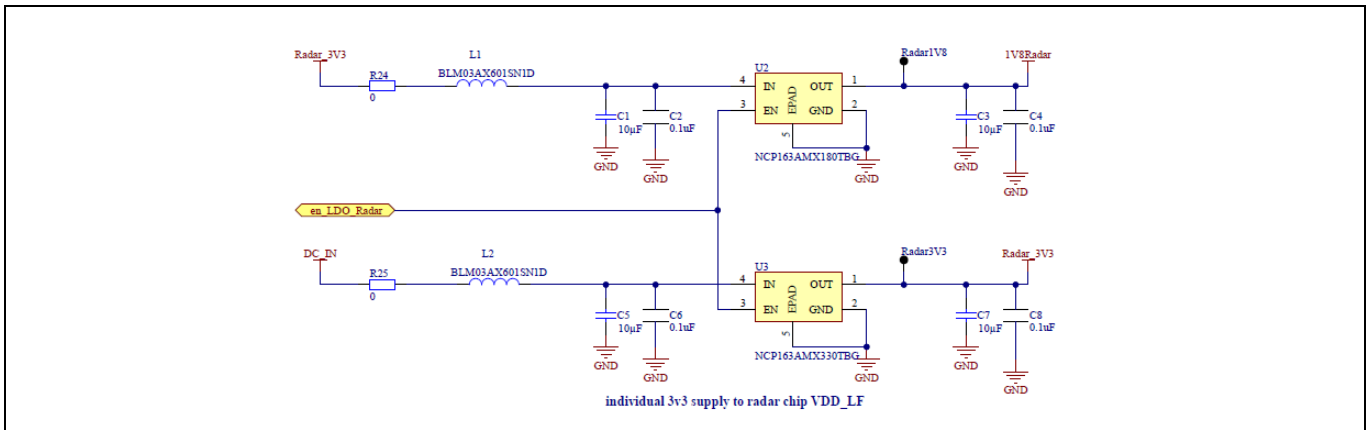

Figure 58 Voltage supply for radar sensor

Table of contents

Figure 59 shows the filter circuit to keep the radar power supply free from spurious emissions.

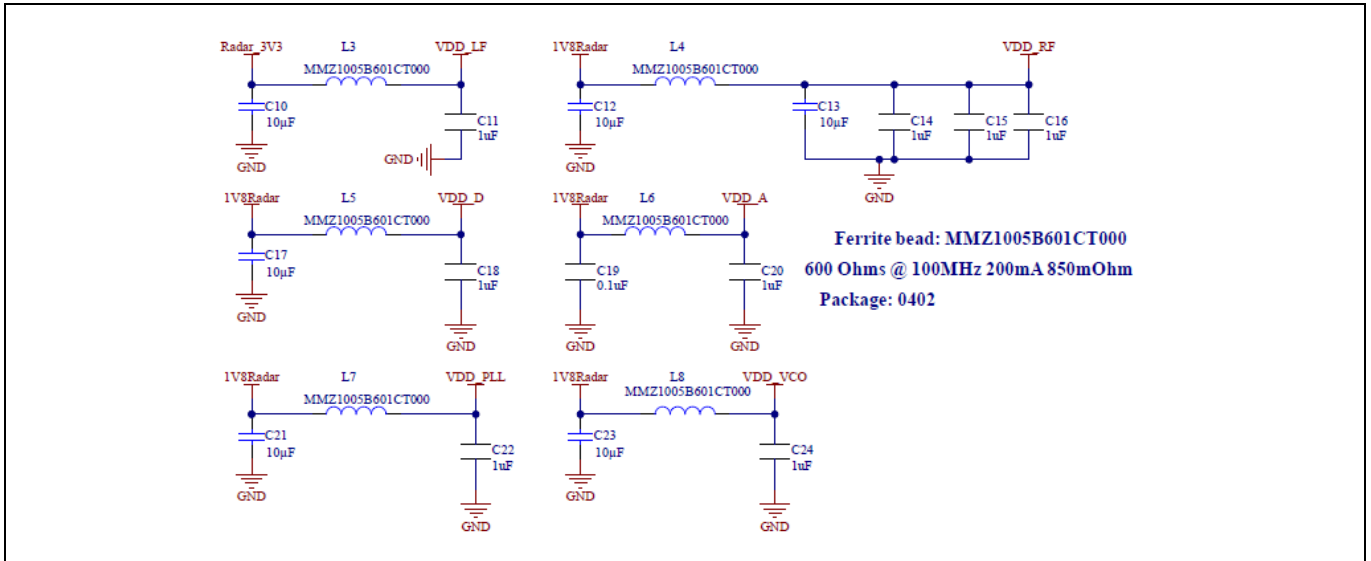

Figure 59 Voltage supply low-pass filters for radar sensor

B1. PCB layout

The size of the XENSIV™ BGT60TR13C radar wing is 43 mm (L) x 23 mm (W).

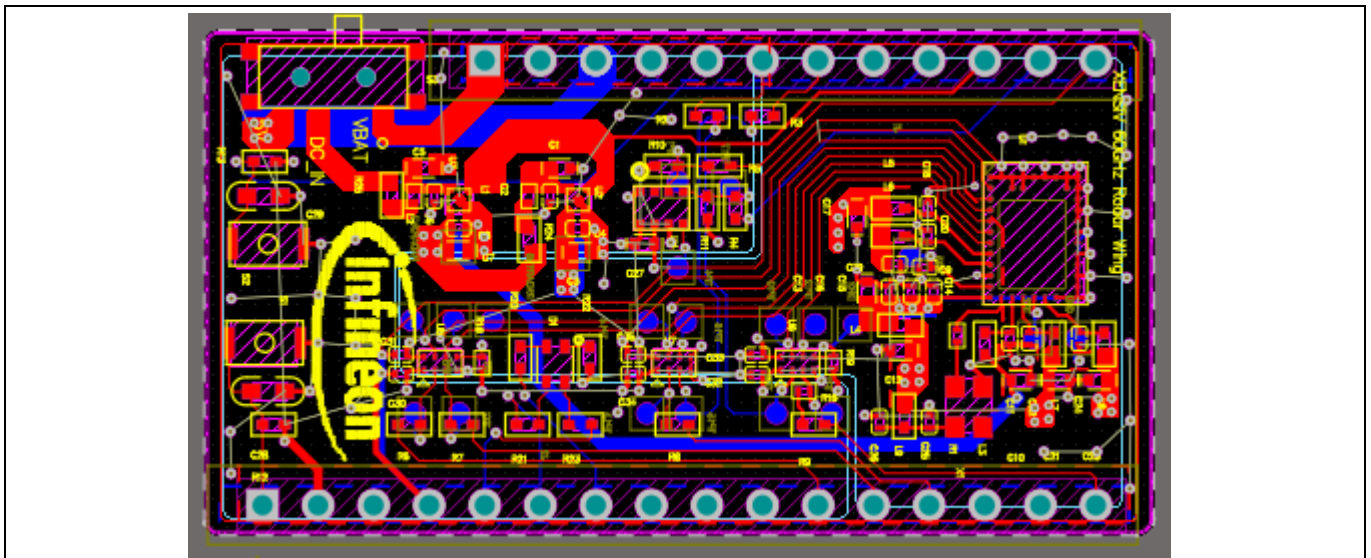

Figure 60 PCB layout of XENSIV™ BGT60TR13C radar wing

C1. Bill of materials

Table 9 BOM

Value	Description	Designator	Manufacturer	Footprint	Part number	Quantity
10 μF	GRM155R60J106ME15D, CER 10 μF 6.3 V X5R 0402	C1, C3, C5, C7, C10, C12, C13, C17, C21, C23	Murata Electronics	0402	GRM155R60J106ME15D	10
0.1 μF	Ceramic capacitor 0.1 μF 10 V X5R 0201, GRM033R61A104ME15D	C2, C4, C6, C8, C19, C30, C31, C32, C33, C34, C35	Murata Electronics	0201	GRM033R61A104ME15D	11

Table of contents

0.47 µF	Ceramic capacitor 0.47 µF 10 V X6S 0201, LMK063BC6474KPLF	C9	Taiyo Yuden	0201	LMK063BC6474KPLF	1
1 µF	Ceramic capacitor 1 µF 6.3 V X5R 0201, GRM033R60J105MEA2D	C11, C14, C15, C16, C18, C20, C22, C24, C26	Murata Electronics	0201	GRM033R60J105MEA2D	9
10 nF	Ceramic capacitor 10000 pF 6.3 V X7R 0201, GRM033R70J103KA01D	C25	Murata Electronics	0201	GRM033R70J103KA01D	1
0.1 µF	Ceramic capacitor 0.1 µF 16 V X7R 0402, GCM155R71C104KA55D	C27	Murata Electronics	0402	GCM155R71C104KA55D	1
100 nF	Ceramic capacitor 0.1 µF 6.3 V X7R 0603	C28, C29	KEMET	0603	C0603C104K9RAC7867	2
APTF1616SEJ3 ZGGVBDC	LED RGB clear 4SMD	D1	Kingbright	RGB_1.6X1.6	APTF1616SEJ3ZGGVBDC	1
Test points	Generic surface mount TP /w 1 mm diameter	DIR1, DIR2, GND, Radar1V8, Radar3V3, TP1, TP2, TP3, TP5, TP6, TP7, TP8, TP9, TP10, TP11, TP12, TP13, TP14, TP15, TP16, TP17	NA	TP SMD	Test point (TP)	21
Header 12H	Header, 12-pin, pitch 2.54 mm	J1	Molex	HDR1X12H	22032121	1
Header 16	Header, 16-pin, pitch 2.54 mm	J2	Molex	HDR1X16	22032161	1
600 Ωs at 100 MHz ferrite bead	Ferrite bead 600 Ω at 100 MHz ferrite bead 0201 (0603 metric) 250 mA 850 mΩ	L1, L2	Murata Electronics	0201	BLM03AX601SN1D	2
600 Ω at 100 MHz ferrite bead	Ferrite bead 600 Ω at 100 MHz signal line ferrite bead 0402 (1005 metric) 200 mA 850 mΩ	L3, L4, L5, L6, L7, L8, L9	TDK Corporation	0402	MMZ1005B601CT000	7
150	Resistor SMD 150 Ω 1% 1/20 W 0201, AC0201FR-07150RL	R1	Yageo	0201	AC0201FR-07150RL	1
0	Resistor SMD 0 Ω jumper 1/16 W 0402 CRG0402ZR	R2, R3, R4, R5, R6, R7, R8, R9	TE Connectivity Passive Product	0402	CRG0402ZR	8
DNP	DNP	R10, R11	NA	DNP	DNP	2
1k	Resistor SMD 1k Ω 5 percent 1/10 W 0402	R12, R13	Panasonic Electronic Components	0402	ERJ-2GEJ102X	2
0	Resistor SMD 0 Ω jumper 1/20 W 0201, CRCW02010000Z0ED	R16	Vishay Dale	0201	CRCW02010000Z0ED	1
1k	ERJ-1GNF1001C, resistor SMD 1k Ω 1 percent 1/20 W 0201	R18, R19	Panasonic Electronic Components	0201	ERJ-1GNF1001C	2
680	RC0402JR-07680RL, resistor SMD 680 Ω 5 percent 1/16 W 0402	R20, R21, R23	Yageo	0402	RC0402JR-07680RL	3
0	RC0402JR-070RL, resistor SMD 0 Ω 5 percent 1/16 W 0402	R22, R24, R25	Yageo	0402	RC0402JR-070RL	3
KXT 311 LHS	KXT 311 LHS, tactile switch SPST-NO 0.02 A 15 V, KXT3 Series ultra low profile top actuated, 100 g, SPST	S1, S2	C&K	KXT3 SPST switch	KXT 311 LHS	2
Slide switch	Slide switch SPDT surface mount, 450404015514	S3	Würth Elektronik		450404015514	1
LSBADR	Generic surface mount TP /w 1 mm diameter	TP4	NA	TP SMD	Test point (TP)	1

XENSIV™ BGT60TR13C	Infineon, 60 GHz radar chip	U1	Infineon	BGT60TR13 C original	BGT60TR13C original	1
NCP163AMX18 0TBG	NCP163AMX180TBG IC linear regulator 1.8 V 250 MA 4XDFN	U2	ON Semiconductor	4-XDFN exposed pad	NCP163AMX180TBG	1
NCP163AMX33 0TBG	NCP163AMX330TBG IC linear regulator 3.3 V 250 MA 4XDFN	U3	ON Semiconductor	4-XDFN exposed pad	NCP163AMX330TBG	1
XENSIV™ DPS368	Digital barometric pressure sensor for portable devices, XENSIV™ DPS368	U4	Infineon	LGA8S145X6 5P2X4_200X 250X100	DPS368	1
74AVCH2T45G T	Voltage level translator bidirectional 1 circuit 2 channel 500 Mbps 8-XSON, SOT833-1 (1.95x1)	U5, U6, U7	Nexperia USA Inc.	SOT833-1	74AVCH2T45GT	3
KC2016 80 MHz	KC2016K80.0000C1GE00, external oscillator XO 80.0000 MHz CMOS SMD	X1	Kyocera International Inc. Electronic Components	4-SMD	KC2016K80.0000C1GE00	1

Appendix B: Frequently asked questions

1. Is the XENSIV™ BGT60TR13C radar wing compatible with other feather-compatible kits?

Yes, the XENSIV™ BGT60TR13C radar wing can be used with any board that has a feather-compatible pin-out.

2. Can we combine the XENSIV™ BGT60TR13C radar wing with other boards, i.e. XENSIV™ PAS CO₂ wing?

Yes, the XENSIV™ PAS CO₂ wing and XENSIV™ BGT60TR13C radar wing boards can be stacked together. It is simple to combine the radar code example, i.e. <https://github.com/Infineon/mtb-example-sensors-radar-presence-freertos> with the XENSIV™ PAS CO₂ code example. Both examples use the FreeRTOS task, which can be easily integrated into a single application.



Revision history

Revision history

Document version	Date of release	Description of changes
V1.0	May 2022	Release version

Trademarks

All referenced product or service names and trademarks are the property of their respective owners.

Edition 2022-23-05

Published by

Infineon Technologies AG

81726 Munich, Germany

© 2022 Infineon Technologies AG.

All Rights Reserved.

Do you have a question about this document?

Email: erratum@infineon.com

Document reference

AppNote Number

IMPORTANT NOTICE

The information contained in this application note is given as a hint for the implementation of the product only and shall in no event be regarded as a description or warranty of a certain functionality, condition or quality of the product. Before implementation of the product, the recipient of this application note must verify any function and other technical information given herein in the real application. Infineon Technologies hereby disclaims any and all warranties and liabilities of any kind (including without limitation warranties of non-infringement of intellectual property rights of any third party) with respect to any and all information given in this application note.

The data contained in this document is exclusively intended for technically trained staff. It is the responsibility of customer's technical departments to evaluate the suitability of the product for the intended application and the completeness of the product information given in this document with respect to such application.

For further information on the product, technology, delivery terms and conditions and prices please contact your nearest Infineon Technologies office (www.infineon.com).

WARNINGS

Due to technical requirements products may contain dangerous substances. For information on the types in question please contact your nearest Infineon Technologies office.

Except as otherwise explicitly approved by Infineon Technologies in a written document signed by authorized representatives of Infineon Technologies, Infineon Technologies' products may not be used in any applications where a failure of the product or any consequences of the use thereof can reasonably be expected to result in personal injury.